

# Installation/Care/Use Manual

Soft Sides™ Fountains with FLEXI-GUARD®

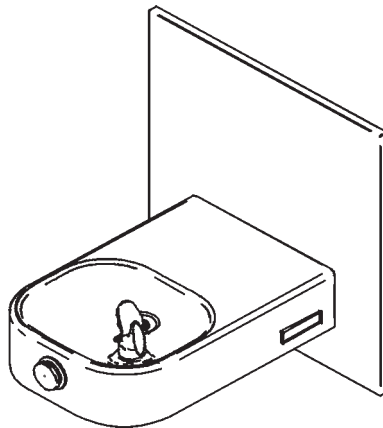

ECDFPW314C

## Installer

To assure you install this model easily and correctly, PLEASE READ THESE SIMPLE INSTRUCTIONS BEFORE STARTING THE INSTALLATION. CHECK YOUR INSTALLATION FOR COMPLIANCE WITH PLUMBING, ELECTRICAL AND OTHER APPLICABLE CODES. After installation, leave these instructions inside the fountain for future reference.

## IMPORTANT

ALL SERVICE TO BE PERFORMED BY AN AUTHORIZED SERVICE PERSON

### IMPORTANT! INSTALLER PLEASE NOTE.

THE GROUNDING OF ELECTRICAL EQUIPMENT SUCH AS TELEPHONE, COMPUTERS, ETC. TO WATER LINES IS A COMMON PROCEDURE. THIS GROUNDING MAY BE IN THE BUILDING OR MAY OCCUR AWAY FROM THE BUILDING. THIS GROUNDING CAN CAUSE ELECTRICAL FEEDBACK INTO A FOUNTAIN, CREATING AN ELECTROLYSIS WHICH CAUSES A METALLIC TASTE OR AN INCREASE IN THE METAL CONTENT OF THE WATER. THIS CONDITION IS AVOIDABLE BY USING THE PROPER MATERIALS AS INDICATED. ANY DRAIN FITTINGS PROVIDED BY THE INSTALLER SHOULD BE MADE OF PLASTIC TO ELECTRICALLY ISOLATE THE FOUNTAIN FROM THE BUILDING PLUMBING SYSTEM.

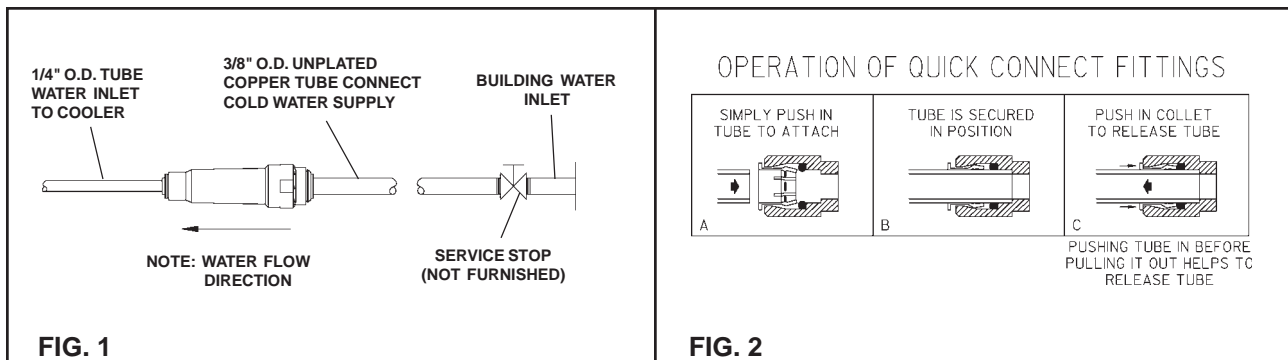

ECDFPW314C

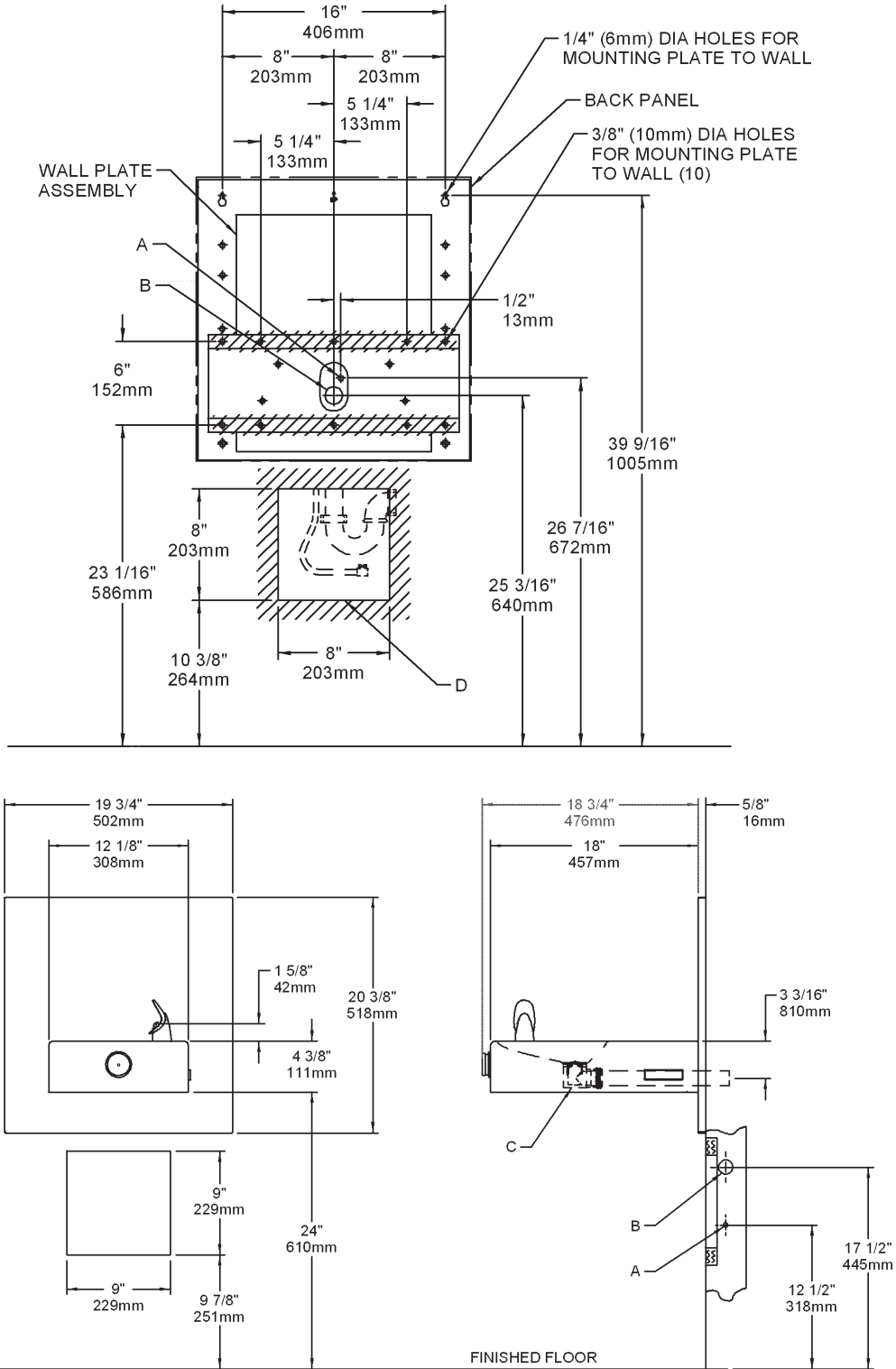

FIG. 3

LEGEND

- A = RECOMMENDED WATER SUPPLY LOCATION 3/8 O.D. UNPLATED COPPER TUBE CONNECT STUBBED 1-1/2" (38mm) FROM WALL SHUT OFF BY OTHERS
- B = RECOMMENDED LOCATION FOR WASTE OUTLET 1-1/4" O.D. DRAIN
- C = 1-1/4" DRAIN FURNISHED
- D = OPENING FOR OPTIONAL AP-99 ACCESS PANEL.

NOTE: REINFORCE THE WALL IN THE SHADED AREAS

**INSTALLATION INSTRUCTIONS**

1. **Wall should already be framed for the fountain** using the positioning dimensions shown in Figure 3. Shown dimensions pertain to installation location (framing must support up to 300 lbs. weight). These dimensions are required for compliance with ANSI Standard A117.0.
2. **Attach wall plate assembly to wall** as shown in Figure 3 using 5/16" x 2" long bolts and flat washers (not provided). Tighten securely. (Fastener must match wall type, i.e. lag screws for wood studs, bolts and anchors for masonry construction.)
3. **Install back panel.** Place the upper edge of the panel above hanger on the wall. Slide panel down until it engages the hanger. Be sure back panel is firmly engaged before releasing it.
4. **Install rough-in plumbing** as shown in Figure 3. Waste line should extend a minimum of 2" (51mm) thru the back panel. Run supply water inlet line thru back panel. Install a service stop (not provided). Turn on supply water and flush thoroughly.
5. **Remove bottom access panel** from fountain basin and save the screws. Install the fountain to the back panel using (4) 5/16" x 3/4" long screws and washers (provided) thru holes in back panel. Tighten securely.
6. **Cut waste tube** to required length using plumbing hardware and a trap (not provided) as a guide. Install hardware and trap. Tighten securely.
7. **Make water supply** connections from service stop to the 3/8" O.D. unplated copper tube coming out of the fountain strainer (See Fig. 1). Turn on water supply and check for leaks. Newly installed water supply line should be insulated after leak check is completed. **DO NOT SOLDER TUBES INSERTED INTO THE STRAINER AS DAMAGE TO THE O-RINGS MAY RESULT.**
8. **These products are designed** to operate on 20-105 PSIG supply line pressure. If inlet pressure is above 105 PSIG, a pressure regulator must be installed in the supply line. Any damage caused by reason of connecting these products to supply line pressure lower than 20 PSIG or higher than 105 PSIG is not covered by warranty.
9. **Check stream height from bubbler.** Stream height is factory set at 35 PSI. If supply pressure varies greatly from this, adjust the screw on regulator item 10 by using a small screwdriver through the small hole in the push button item 3 (See Fig.5). Clockwise adjustment will raise stream height and counter-clockwise adjustment will lower stream height. For best adjustment stream should hit basin approximately 6-1/2" (165mm) from bubbler.
10. **Replace bottom access** panel to fountain basin using screws provided. Tighten securely.

**TROUBLE SHOOTING AND MAINTENANCE**

1. **Orifice Assy:** Mineral deposits on orifice can cause water flow to spurt or not regulate. Mineral deposits may be removed from orifice with a small round file not over 1/8" diameter or a small diameter wire.  
**CAUTION:** Do not file or cut orifice materials.
2. **Stream Regulator:** If orifice is free of material deposits, regulate flow according to instruction 9 stated above.
3. **Actuation of Quick Connect Water Fittings:** Cooler is provided with lead-free connectors which utilize an o-ring water seal. To remove tubing from the fitting, relieve water pressure, push in on the gray collar while pulling on the tubing (See Figure 2). To insert tubing, push tube straight into the fitting until it reaches a positive stop, approximately 3/4".

ECDFPW314C ECDFPWVR314C

PARTS LIST		
ITEM NO.	PARTNO.	DESCRIPTION
1	40575C	Drain - Strainer
2	15005C	Retaining Nut
3	45662C	Push Button
4	45737C	Push Button Sleeve
5	50986C	Regulator Holder
6	40322C	Orifice Assy
7	56011C	Housing Assy
8	55997C	Pedestal
9	75580C	Bubbler Locknut
10	61313C	Regulator
11	75672C	Cap Screw
12	112627543890	Screw - #10-24 X .50 PHTC
13	55996C	Strainer
14	55001129	Fountain Arm - Long
15	55000665	Bottom Cover Plate - Long
16	28290C	Back Panel
17	40045C	Hex Nut
18	28291C	Regulator Mounting Bracket
19	100322740560	Gasket (VR Model Only)
20	15009C	Bubbler - Nipple (VR Model Only)
21	45392C	Bubbler (VR Model Only)
22	56092C	Poly Tubing (Cut To Length)
23	28286C	Mounting Plate Assy
24	45679C	Drain Tailpipe
25	45805C	Drain Adapter
26	50074C	Gasket - Tail Pipe
27	60295C	Tube - Water In
28	45736C	Nut-Regulator Mounting
29	75541C	Washer - Flat .339/.359ID Steel
30	111577243890	Screw - Mach. 5/16-18 x 3/4

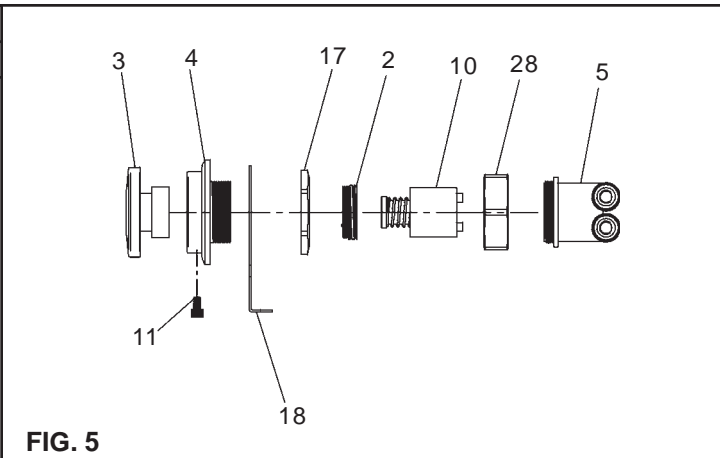

FIG. 5

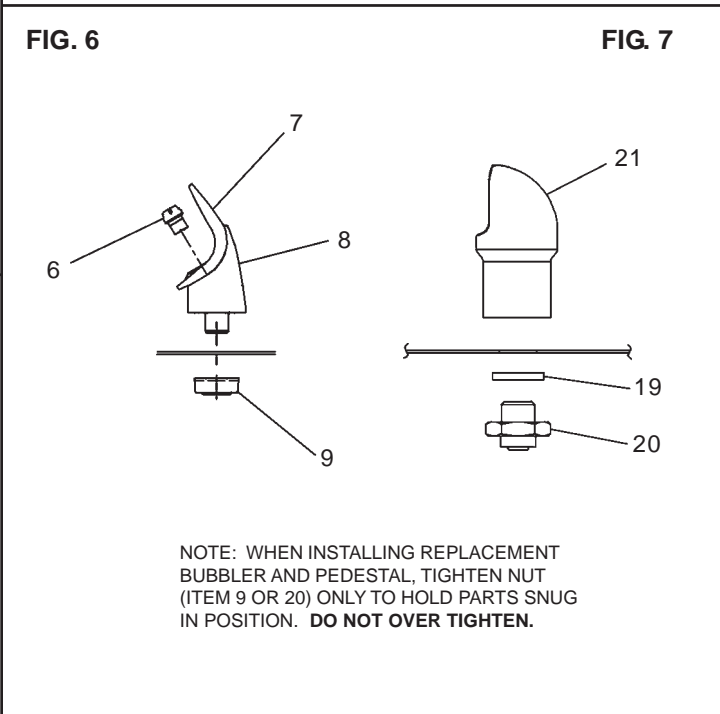

FIG. 6

FIG. 7

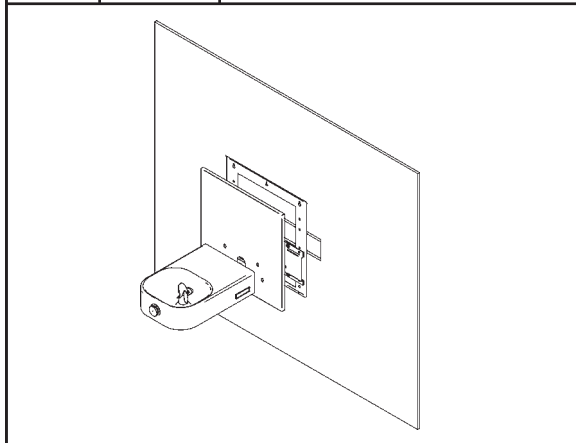
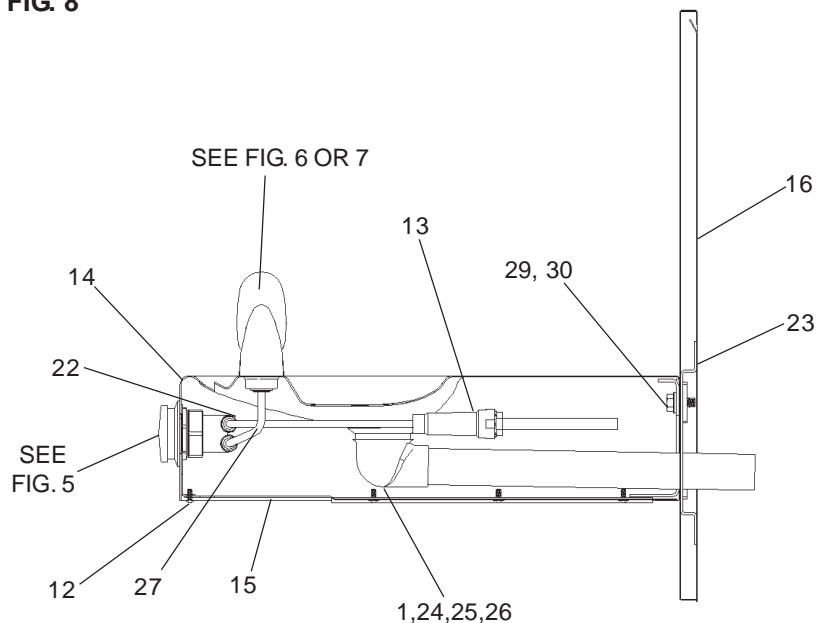

FIG. 8



FOR PARTS, CONTACT YOUR LOCAL DISTRIBUTOR OR CALL 1.800.323.0620  
 ELKAY MANUFACTURING COMPANY • 2222 CAMDEN COURT • OAK BROOK, IL 60523 • 630.574.8484