

# Installation/Care/Use Manual

## Semi-Recessed Wall Mount Fountain with FLEXI-GUARD®

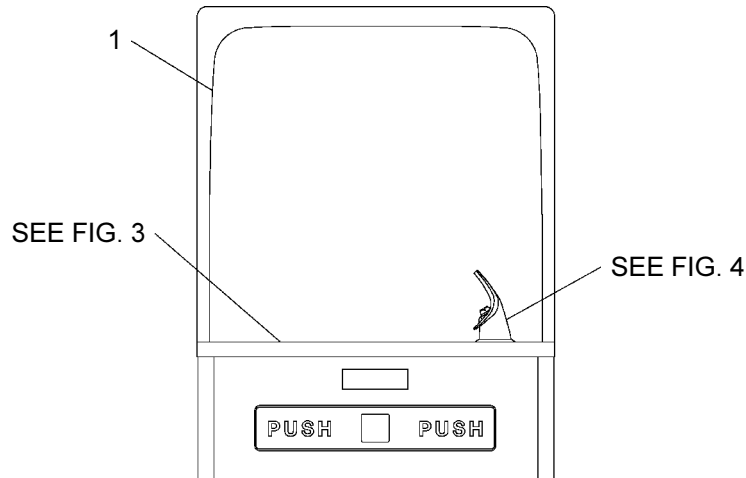

### Installer

To assure you install this model easily and correctly, PLEASE READ THESE SIMPLE INSTRUCTIONS BEFORE STARTING THE INSTALLATION. CHECK YOUR INSTALLATION FOR COMPLIANCE WITH PLUMBING, ELECTRICAL AND OTHER APPLICABLE CODES. After installation, leave these instructions inside the fountain for future reference.

### IMPORTANT

ALL SERVICE TO BE PERFORMED BY AN AUTHORIZED SERVICE PERSON

### IMPORTANT! INSTALLER PLEASE NOTE.

THE GROUNDING OF ELECTRICAL EQUIPMENT SUCH AS TELEPHONE, COMPUTERS, ETC. TO WATER LINES IS A COMMON PROCEDURE. THIS GROUNDING MAY BE IN THE BUILDING OR MAY OCCUR AWAY FROM THE BUILDING. THIS GROUNDING CAN CAUSE ELECTRICAL FEEDBACK INTO A FOUNTAIN, CREATING AN ELECTROLYSIS WHICH CAUSES A METALLIC TASTE OR AN INCREASE IN THE METAL CONTENT OF THE WATER. THIS CONDITION IS AVOIDABLE BY USING THE PROPER MATERIALS AS INDICATED. ANY DRAIN FITTINGS PROVIDED BY THE INSTALLER SHOULD BE MADE OF PLASTIC TO ELECTRICALLY ISOLATE THE FOUNTAIN FROM THE BUILDING PLUMBING SYSTEM.

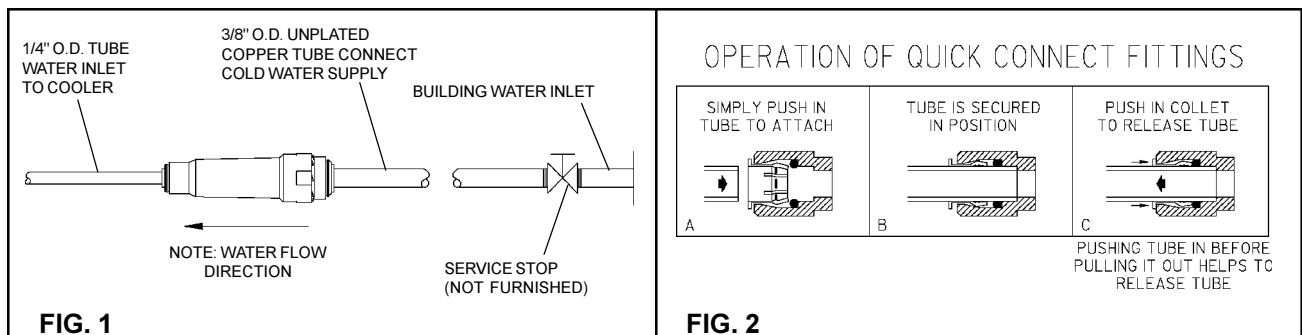

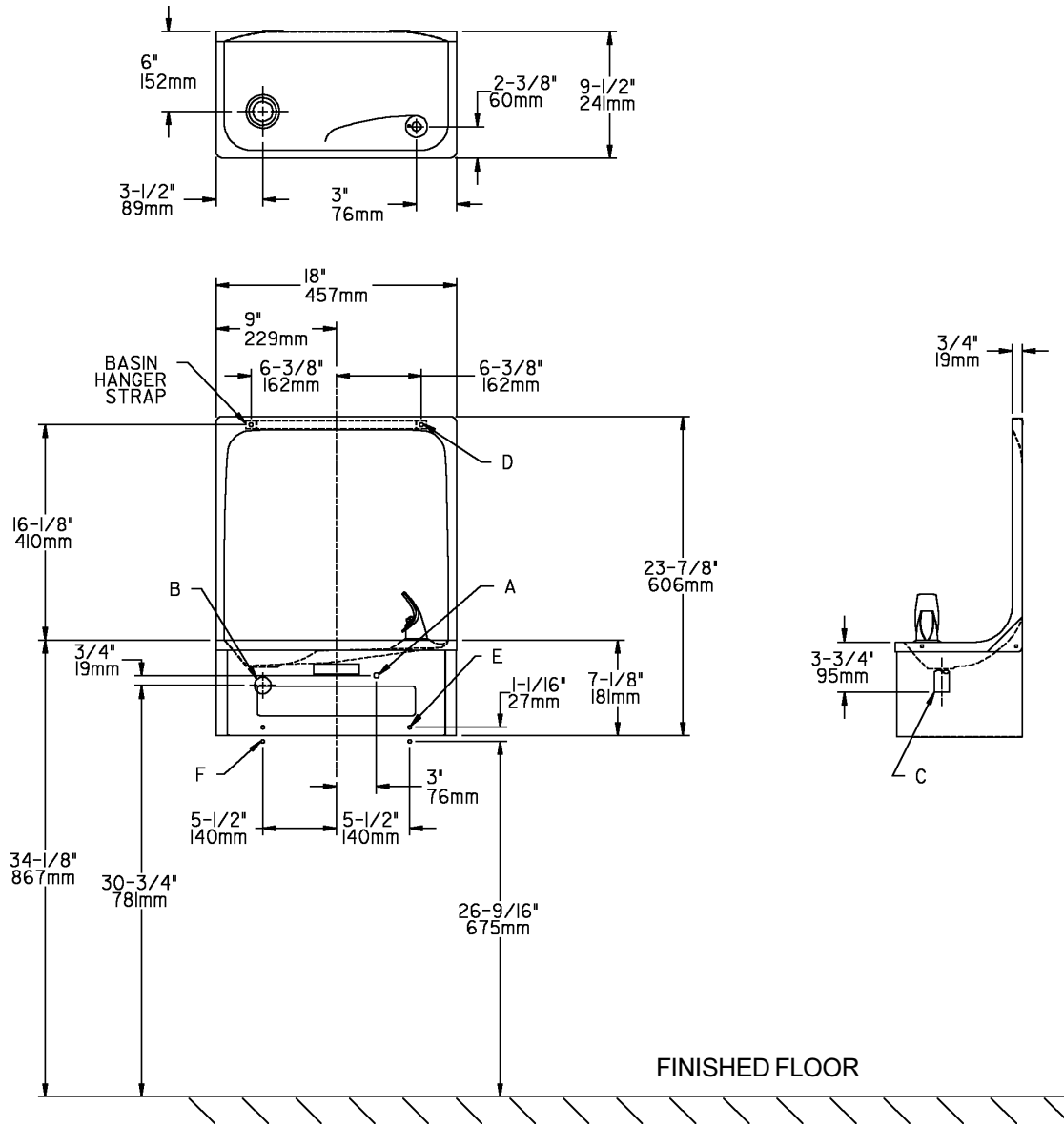

**LEGEND:**

**A = RECOMMENDED WATER SUPPLY LOCATION, 3/8 O.D. UNPLATED COPPER TUBE CONNECT.**

**B = RECOMMENDED LOCATION FOR WASTE OUTLET, 1-1/4" O.D. DRAIN.**

**C = 1-1/4" TRAP NOT FURNISHED.**

**D = MOUNTING HOLES FOR BASIN HANGER STRAP.**

**E = MOUNTING HOLES FOR FOUNTAIN (VANDAL RESISTANT INSTALLATION ONLY).**

**F = MOUNTING HOLES FOR FOUNTAIN (EASY ACCESS INSTALLATION ONLY).**

## INSTALLATION INSTRUCTIONS

- 1. Connecting** lines to be unplated copper and thoroughly flushed to remove all foreign matter before connection to fountain.
- 2. Make** water supply connections from service stop to the 3/8" O.D. unplated copper tube coming out of the strainer. Turn on water supply and check for leaks. Newly installed water supply line should be insulated after leak check is completed. **DO NOT SOLDER TUBES INSERTED INTO THE STRAINER AS DAMAGE TO THE O-RINGS MAY RESULT.**
- 3. These** products are designed to operate on 20-105 PSIG supply line pressure. If inlet pressure is above 105 PSIG, a pressure regulator must be installed in the supply line. Any damage caused by reason of connecting these products to supply line pressures lower than 20 PSIG or higher than 105 PSIG is not covered by warranty.
- 4. Check** stream height from bubbler. Stream height is factory set at 35 PSI. If supply pressure varies greatly from this, turn adjustment screw on the regulator (Item 19). Clockwise adjustment will raise stream height and counter-clockwise will lower stream height. For best adjustment stream should hit basin approximately 6-1/2" (165mm) from bubbler.

## TROUBLE SHOOTING AND MAINTENANCE

- 1. Orifice Assy:** Mineral deposits on orifice can cause water flow to spurt or not regulate. Mineral deposits may be removed from orifice with a small round file not over 1/8" diameter or a small diameter wire.  
**CAUTION:** Do not file or cut orifice materials.
- 2. Stream Regulator:** If orifice is free of material deposits, regulate flow according to instruction 4 stated above.
- 3. Actuation of Quick Connect Water Fittings:** Cooler is provided with lead-free connectors which utilize an o-ring water seal. To remove tubing from the fitting, relieve water pressure, push in on the gray collar while pulling on the tubing (See Figure 2). To insert tubing, push tube straight into the fitting until it reaches a positive stop, approximately 3/4".
- 4. CAUTION:** Cleaning of Bronzetone Models requires special care. Outer surfaces must be cleaned with a mild detergent or a mixture of vinegar and water only, rinsed and wiped dry. Abrasive and acidic cleaners may eventually damage the Bronzetone finish.

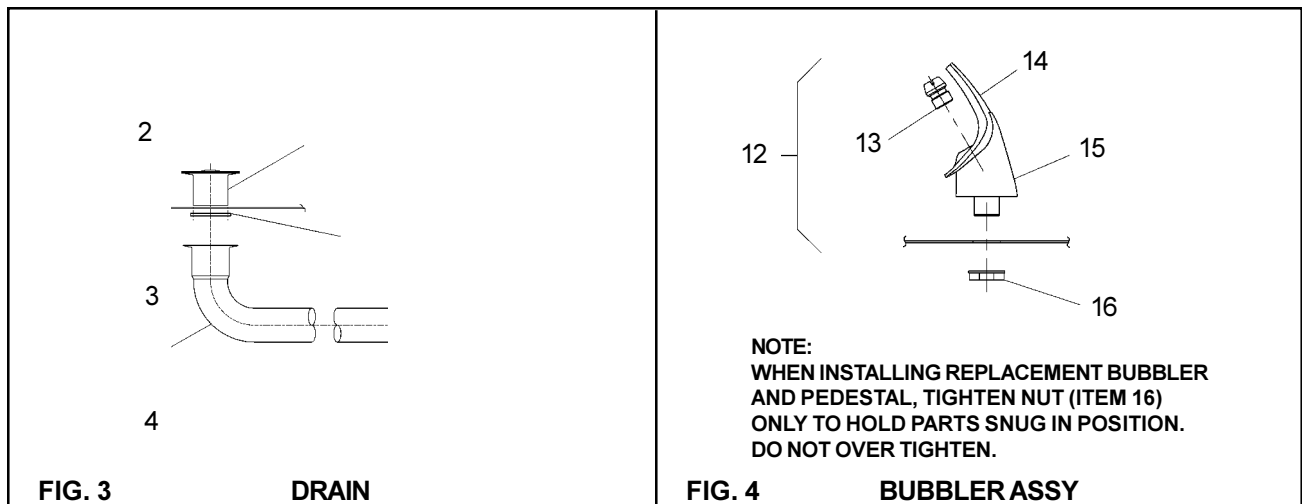

EDFP19C\*A

PARTS LIST		
ITEM NO.	PART NO.	DESCRIPTION
1	21222C	Basin
2	40575C	Strainer & Ferrule Assy
3	50074C	Gasket - Tailpipe
4	40572C	Tailpipe
5	22905C	Panel - Left Hand Side
6	22907C	Panel - Right Hand Side
7	22718C	Panel - Front
8	21560C	Panel - Access
9	22611C	Baseplate
10	21708C	Push Bar Assy
11	22574C	Regulator Mounting Bracket
12	56073C	Bubbler Assy
13	40322C	Orifice Assy
14	56011C	Housing Assy
15	55997C	Pedestal
16	75580C	Locknut 3/8-18
17	40045C	Hex Nut 1-5/16
18	15005C	Retaining Nut
19	61314C	Regulator
20	50986C	Regulator - Holder
21	75555C	Clip
22	50198C	Bushing - Nylon
23	70278C	Rod - Support
24	21710C	Angle - Wall Mounting
NS	20415C	Basin Hanger Strap
NS	55996C	Strainer

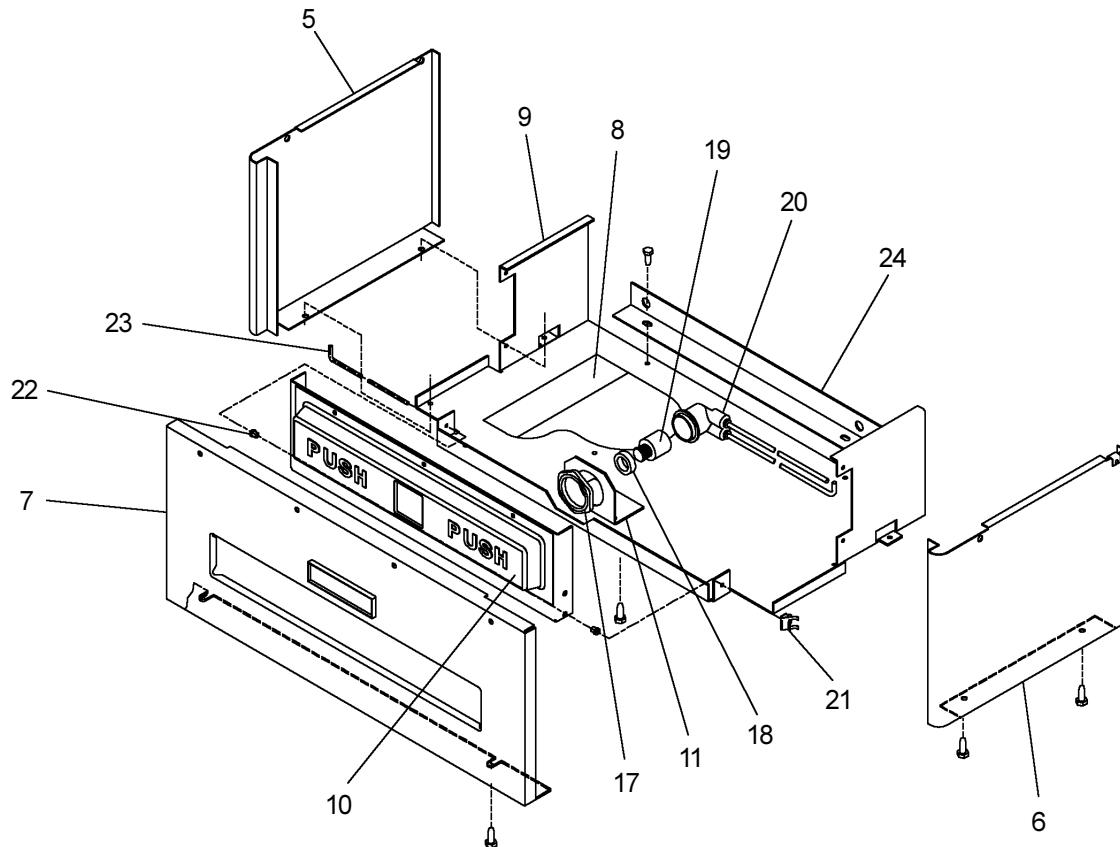

FOR PARTS, CONTACT YOUR LOCAL DISTRIBUTOR OR CALL 1.800.323.0620  
 ELKAY MANUFACTURING COMPANY • 2222 CAMDEN COURT • OAK BROOK, IL 60523 • 630.574.8484