

Installation / Care / Use Manual

Refrigeration Package

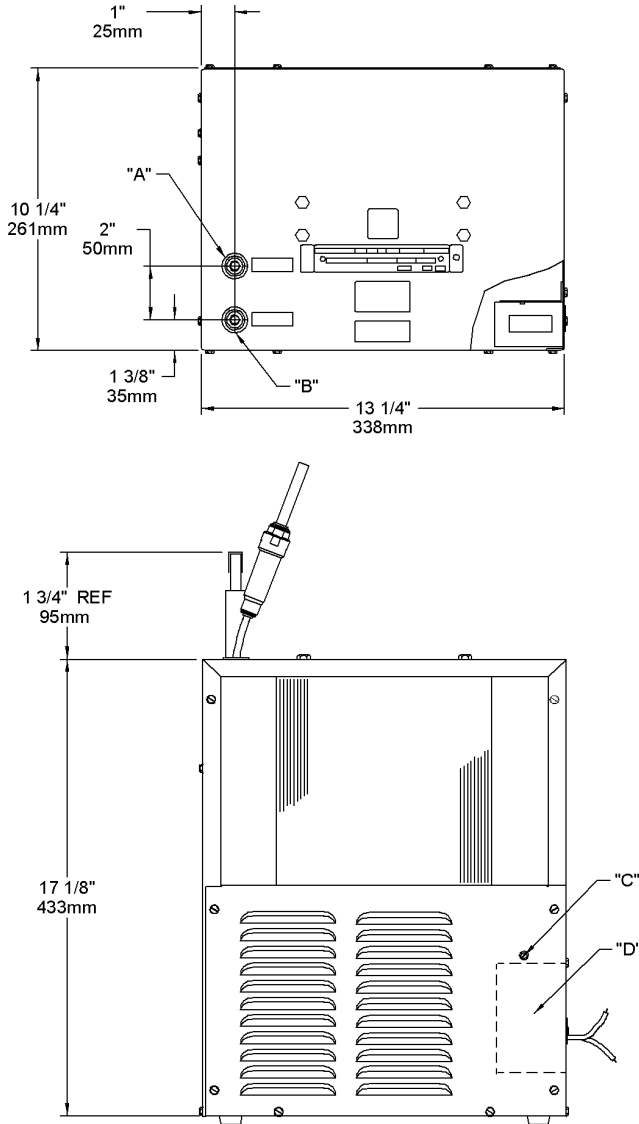

LEGEND
A = 1/4" O.D. TUBE WATER OUTLET
B = 1/4" O.D. TUBE WATER INLET
C = TEMPERATURE ADJUSTMENT
D = ELECTRICAL

INSTALLATION

1. When mounting unit in an open area, to insure proper ventilation, maintain a 4" (102mm) clearance from cabinet louvers on each side of cooler. When mounting unit in a cavity or behind a wall maintain minimum space of 4" (102mm) on each side, 4" (102mm) on the top and a depth of 12" (305mm).
2. Water inlet is 1/4" (6 mm) O.D. tube. Contractor to supply the connections as required.
3. Connecting lines to be of unplated copper, thoroughly flushed to remove all foreign matter before being connected to cooler. If flushing does not remove all particles, a water strainer should be installed in supply line. This cooler is manufactured in such a manner that it does not in any way cause taste, odor, color or sediment problems. If a taste, odor or sediment problem is prevalent, try installing our water filter module, Part No. 731524251550, on the supply line.
4. Connect cooler to building supply line with a shut-off valve and install the in-line strainer between the valve and cooler.
5. Electrical: Make sure power supply is identical in voltage, cycle, and phase to that specified on cooler serial plate. Never wire compressor directly to the power supply.
6. This chiller has been designed for use with potable water **ONLY**.

START-UP

1. Open supply line valve.
2. Purge air from all water lines by operating bubbler valve of fountain to which cooler is connected. Steady stream assures all air is removed.
3. Rotate fan to insure proper clearance and free fan action.
4. Connect to electrical power.

TROUBLE SHOOTING & MAINTENANCE

Temperature Control: Factory set at 50°F (± 5°) under normal conditions. For colder water, adjust screw on item no. 12 in clockwise direction.

Ventilation: Cabinet louvers and condenser fins should be periodically cleaned with brush, air hose or vacuum cleaner. Excess dirt or poor ventilation can cause no cold water and compressor cycling on the compressor overload protector.

Lubrication: Motors are lifetime lubricated.

Actuation of Quick Connect Water Fittings: Cooler is provided with lead-free connectors which utilize an o-ring seal. To remove tubing from the fittings, relieve water pressure, push in on gray collar while pulling on the tubing. To insert tubing, push tube straight into fitting until it reaches a positive stop, approximately 3/4".

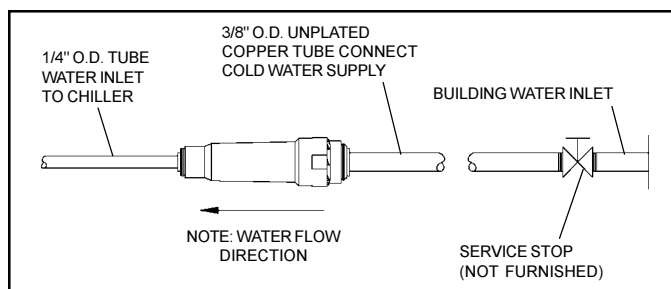

OPERATION OF QUICK CONNECT FITTINGS

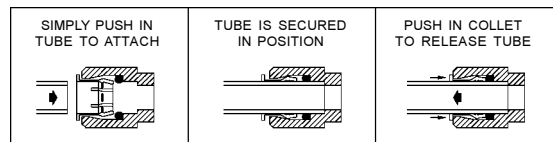

PUSHING TUBE IN BEFORE PULLING IT OUT HELPS TO RELEASE TUBE

ITEMIZED PARTS LIST		
ITEM NO.	PART NO.	DESCRIPTION
1	66505C	EVAPORATOR TANK ASSY
2	22301C	CABINET
3	61942C	CONDENSER
4	31491C	MOTOR - FAN 115V
5	20437C	BRACKET - FAN MOUNTING
6	30699C	BLADE - FAN
7	70018C	NUT - FAN BLADE
8	22309C	SHROUD - FAN
9	66530C	HEAT EXCHANGER
10	66202C	DRIER
*11	36094C	COMPRESSOR SERVICE PAK
12	31513C	COLD CONTROL
13	22299C	PANEL - FRONT
14	35768C	COVER - RELAY
15	36158C	OVERLOAD
16	35959C	RELAY
17	100806740570	GROMMET
18	101516143550	STUD - COMP. MOUNTING
19	19037000	CLIP
20	50930C	BUMPER
21	27303C	BASEPLATE
22	22300C	PANEL - REAR
23	55996C	IN-LINE STRAINER
NS	70745C	UNION 1/4 X 3/8

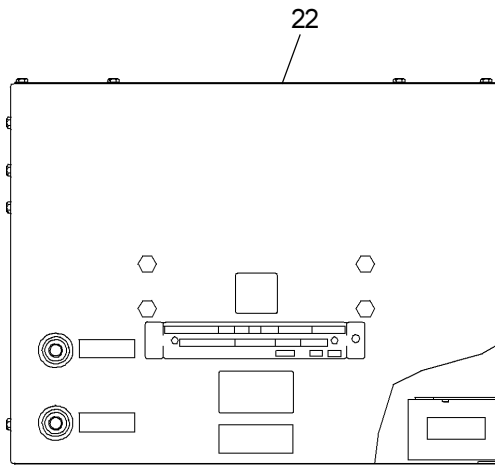

220V - 50 HZ

ITEM NO.	PART NO.	DESCRIPTION
4	31430C	MOTOR - FAN 220V
9	66530C	HEAT EXCHANGER
*11	36085C	COMPRESSOR SERVICE PAK
15	36049C	OVERLOAD
16	36050C	RELAY

*INCLUDES RELAY & OVERLOAD. IF UNDER WARRANTY, REPLACE WITH SAME COMPRESSOR USED IN ORIGINAL ASSEMBLY.

NOTE: All correspondence pertaining to any of the above water cooler or orders for repair parts MUST include model number and serial number of cooler, name and part number of replacement part.

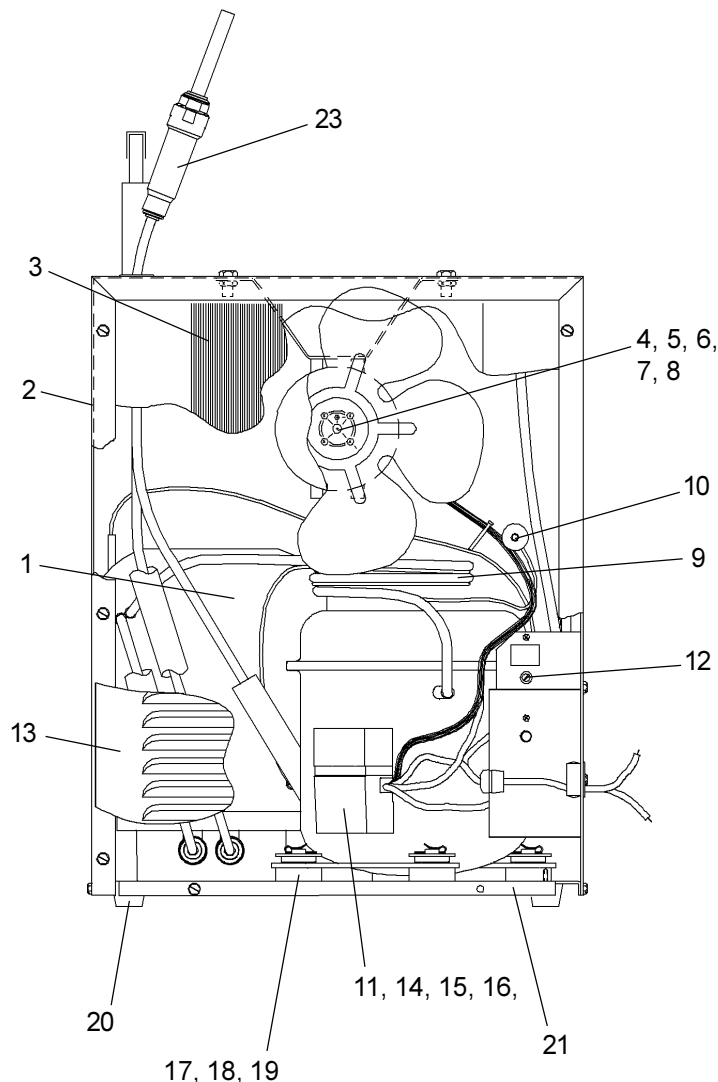

WIRING DIAGRAM

