

Halsey Taylor Owners Manual

Models: HT-EBP1, HT-SBP1, HT-SEBP1

Non-Refrigerated Fountains with Back Panels

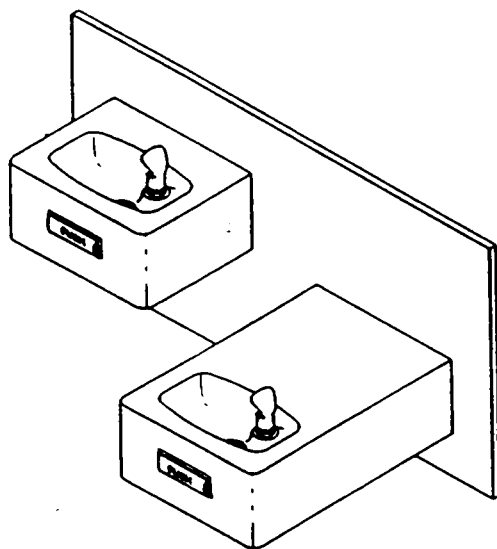

HT-SEBP1

Installer

To assure you install this model easily and correctly,
**PLEASE READ THESE SIMPLE INSTRUCTIONS BEFORE STARTING THE
INSTALLATION. CHECK YOUR INSTALLATION FOR COMPLIANCE WITH
PLUMBING, ELECTRICAL AND OTHER APPLICABLE CODES.** After install-
ation, leave these instructions inside the cooler for future reference.

IMPORTANT

ALL SERVICE TO BE PERFORMED BY AN AUTHORIZED SERVICE PERSON

Installation: HT-EBP1	Page 2
Installation: HT-SBP1	Page 3
Installation: HT-SEBP1	Page 4
Parts List: HT-EBP1, HT-SBP1 and HT-SEBP1	Page 7
Care of Golden Bronzestone Models.	Page 8

DIMENSIONS SHOWN LOCATE WASTE LINE HOLE, 1 1/4" (32 mm) DIA. HOLE, INLET LINE, 3/8" (22 mm) DIA. HOLE, HANGER BRACKET AND FOUNTAIN MOUNTING HOLES

HT-EBP1 BARRIER-FREE FOUNTAIN WITH BACK PANEL

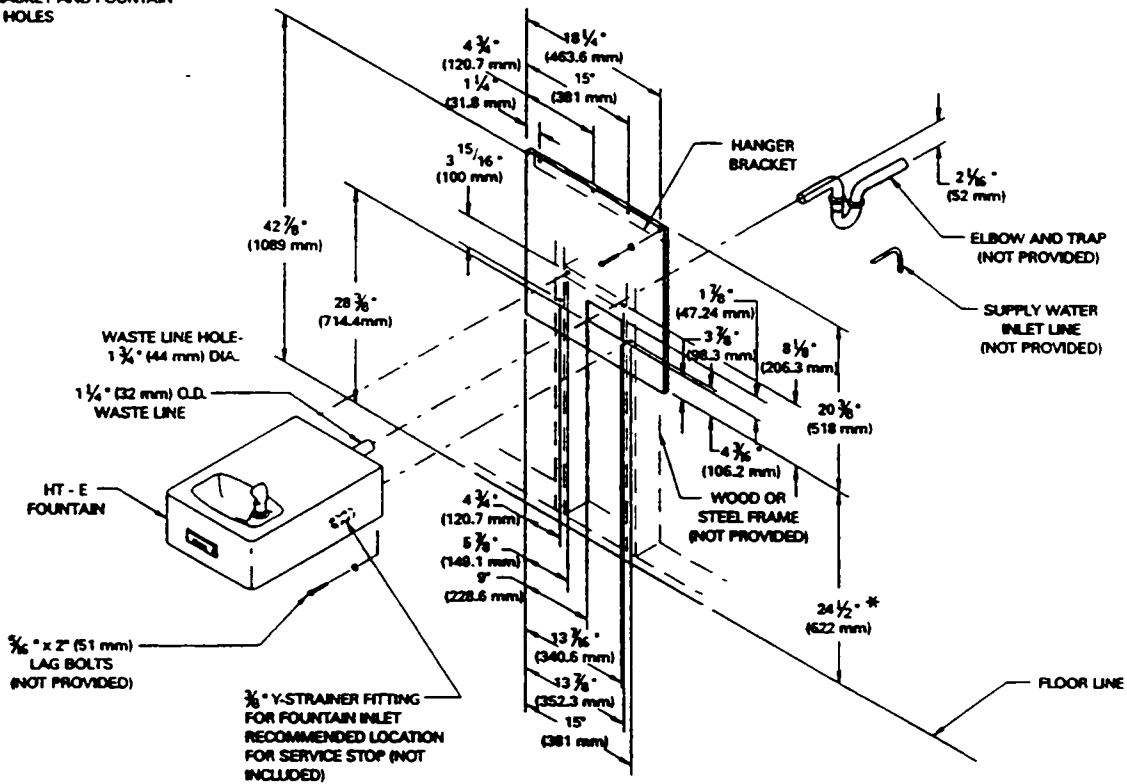

* 24 1/2" (622 mm) required to obtain a projector orifice height of 35 3/4" (908 mm) for wheelchair users. When installing this unit, LOCAL, STATE and FEDERAL CODES should be adhered to and dimensions adjusted accordingly.

OPERATING PRESSURE:
Supply water - 90 PSI Maximum

FIG.

1. Wall should already be framed for the fountain using the positioning dimensions shown in Figure 1. Shown dimensions pertain to installation location (framing must support up to 150 lbs. weight). These dimensions are required for compliance with ANSI Standard A117.0 (Framing shown for reference only).
2. Make wall access cutout as shown in Figure 2. Be sure that bottom surface is level to the floor and will not protrude below bottom edge of back panel.
3. Attach hanger bracket to wall and level as shown in Figure 1. Using four (4) 5/16" x 2" (51 mm) long bolts and flat washers (not provided). Tighten securely.
4. Install back panel. Place the upper edge of the panel above hanger on the wall. Slide the panel down until it engages the hanger. Be sure back panel is firmly engaged before releasing it.
5. Install rough-in plumbing as shown in Figure 1. Waste line should extend a minimum of 2" (51 mm) through the back panel. Run supply water inlet line through back panel. Install a service stop (not provided). Turn on supply water and flush thoroughly.
6. Remove bottom access panel from fountain basin and save the screws. Install the fountain to the back panel and wall using four (4) 5/16" x 2" (51 mm) long lag bolts and washers (not provided) through holes in back panel. Tighten securely.
7. Cut waste tube to required length using plumbing hardware and trap (not provided) as a guide. Install hardware and trap. Tighten securely.

8. Make water supply connections from service stop to the fountain Y-strainer. Insert water line to positive stop approximately 3/4" (19 mm) on inlet side of Y-strainer. (See figure 8). Turn on water supply and check for leaks. Newly installed water supply line should be insulated after leak check is completed.
9. Check stream height from bubbler. Stream height is factory set at 45 - 50 PSI. If supply pressure varies greatly from this, adjust screw on regulator (Item 13 on page 5). Clockwise adjustment will raise stream height and CCW adjustment will lower stream height. For best adjustment stream height should be approximately 1 1/2" (38 mm) above the bubbler guard. (See Figure 7 and 10 on page 5)
10. Water Valve Mechanism - ADJUSTMENT PROCEDURE:
 - Turn adjustment screw (Item #7, figure 7, page 5) "Counter-Clock-wise" until water flow from bubbler starts.
 - Turn adjustment screw "Clockwise" until water flow stops, Then turn an additional 1/2 turn.
11. Replace bottom access panel to fountain basins using screws provided. Tighten securely.

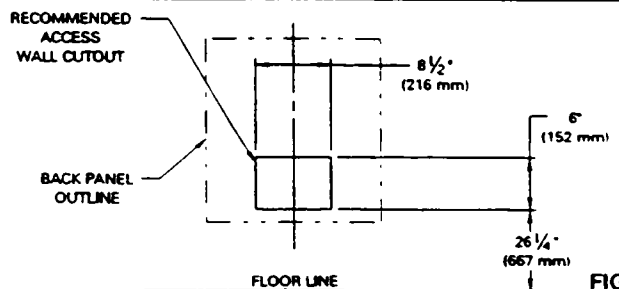
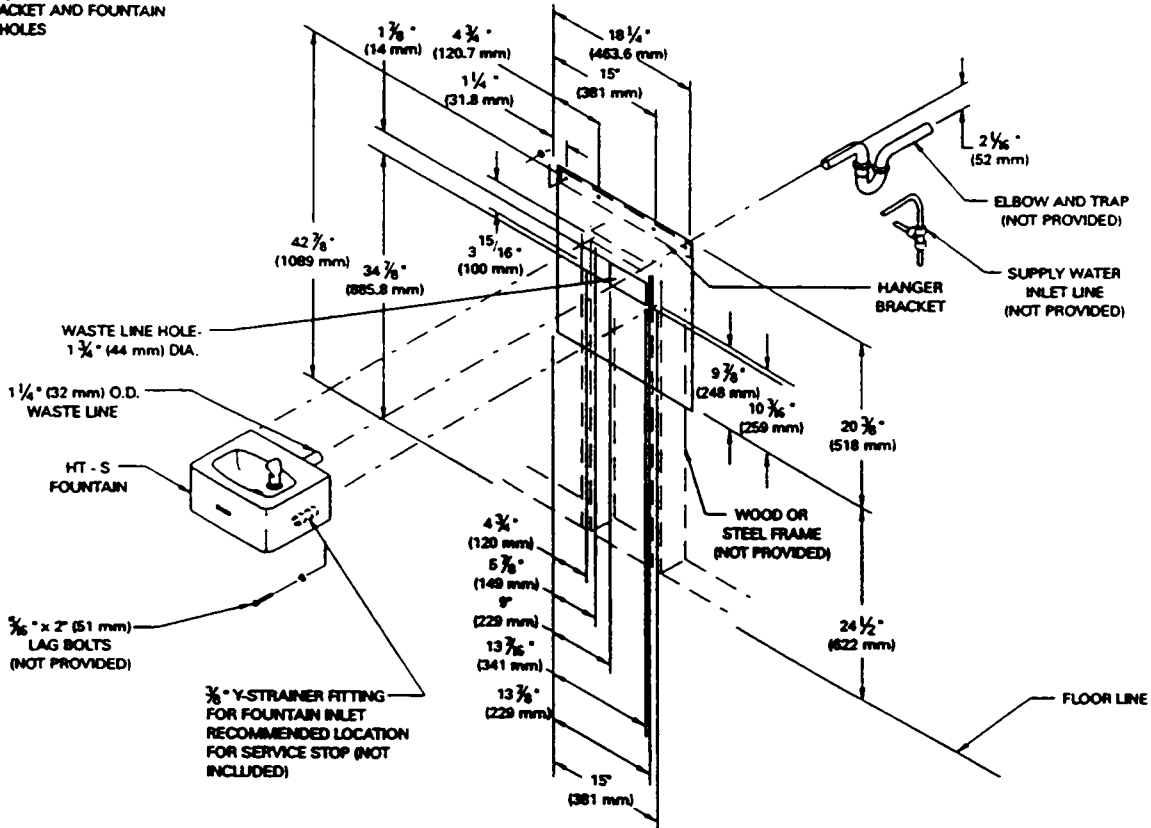

FIG. 2

DIMENSIONS SHOWN LOCATE WASTE LINE HOLE, $1\frac{1}{4}$ " (32 mm) DIA. HOLE, INLET LINE, $\frac{3}{8}$ " (22 mm) DIA. HOLE, HANGER BRACKET AND FOUNTAIN MOUNTING HOLES

HT-SBP1 FACE MOUNTED FOUNTAIN WITH BACK PANEL



OPERATING PRESSURE:
water - 90 PSI Maximum

When installing this unit, LOCAL, STATE and FEDERAL CODES should be adhered to and dimensions adjusted accordingly.

FIG. 3

1. Wall should already be framed for the fountain using the positioning dimensions shown in Figure 3. Shown dimensions pertain to installation location (framing must support up to 150 lbs. weight). These dimensions are required for compliance with ANSI Standard A117.0 (Framing shown for reference only).
2. Make wall access cutout as shown in Figure 4. Be sure that bottom surface is level to the floor and will not protrude below bottom edge of back panel.
3. Attach hanger bracket to wall and level as shown in Figure 3. Using four (4) $\frac{5}{16}$ " x 2" (51 mm) long bolts and flat washers (not provided). Tighten securely.
4. Install back panel. Place the upper edge of the panel above hanger on the wall. Slide the panel down until it engages the hanger. Be sure back panel is firmly engaged before releasing it.
5. Install rough-in plumbing as shown in Figure 3. Waste line should extend a minimum of 2" (51 mm) through the back panel. Run supply water inlet line through back panel. Install a service stop (not provided). Turn on supply water and flush thoroughly.
6. Remove bottom access panel from fountain basin and save the screws. Install the fountain to the back panel and wall using four (4) $\frac{5}{16}$ " x 2" (51 mm) long lag bolts and washers (not provided) through holes in back panel. Tighten securely.
7. Cut waste tube to required length using plumbing hardware and trap (not provided) as a guide. Install hardware and trap. Tighten securely.

8. Make water supply connections from service stop to the fountain Y-strainer. Insert water line to positive stop approximately $\frac{3}{4}$ " (19 mm) on inlet side of Y-strainer. (See figure 8). Turn on water supply and check for leaks. Newly installed water supply line should be insulated after leak check is completed.
9. Check stream height from bubbler. Stream height is factory set at 45 - 50 PSI. If supply pressure varies greatly from this, adjust screw on regulator (Item 13). Clockwise adjustment will raise stream height and CCW adjustment will lower stream height. For best adjustment stream height should be approximately $1\frac{1}{2}$ " (38 mm) above the bubbler guard. (See Figure 7 and 9 on page 5)
10. Water Valve Mechanism - ADJUSTMENT PROCEDURE:
 - Turn adjustment screw (Item #9, figure 7, page 5) "Counter-Clock-wise" until water flow from bubbler starts.
 - Turn adjustment screw "Clockwise" until water flow stops, Then turn an additional $\frac{1}{2}$ turn.
11. Replace bottom access panel to fountain basins using screws provided. Tighten securely.

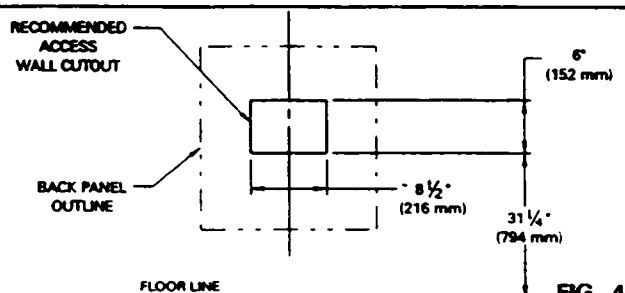
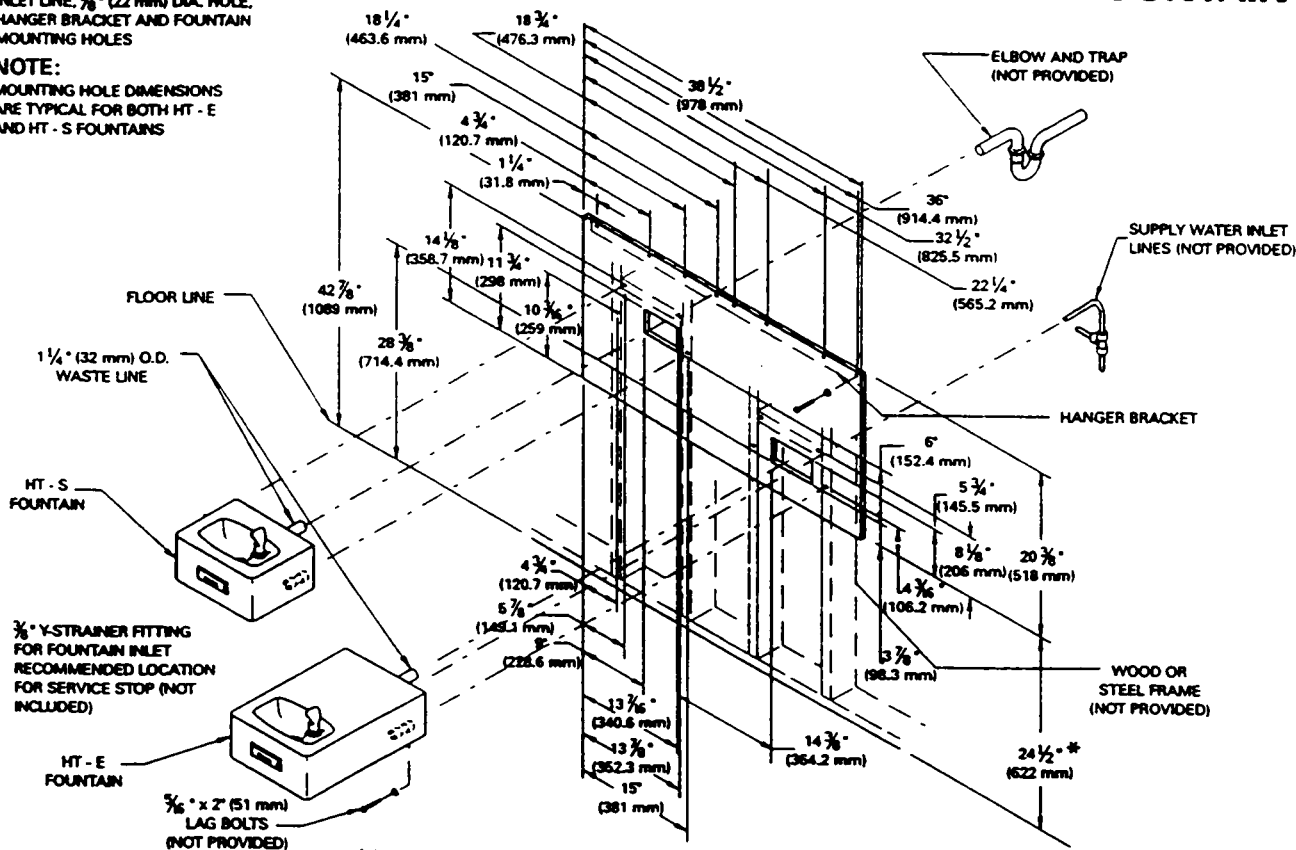

FIG. 4

HT-SEBP1 BARRIER-FREE BI-LEVEL FOUNTAIN

DIMENSIONS SHOWN LOCATE WASTE LINE HOLE. 1 1/4" (32 mm) DIA. HOLE. INLET LINE. 3/8" (22 mm) DIA. HOLE. HANGER BRACKET AND FOUNTAIN MOUNTING HOLES

NOTE:
MOUNTING HOLE DIMENSIONS ARE TYPICAL FOR BOTH HT - E AND HT - S FOUNTAINS



* 24 1/2" (622 mm) required to obtain a projector orifice height of 35 3/4" (908 mm) for wheelchair users. When installing this unit, LOCAL, STATE and FEDERAL CODES should be adhered to and dimensions adjusted accordingly.

OPERATING PRESSURE:
Supply water - 90 PSI Maximum

FIG. 5

1. Wall should already be framed for the fountains using the positioning dimensions shown in Figure 5. Shown dimensions pertain to installation location (framing must support up to 300 lbs. weight). These dimensions are required for compliance with ANSI Standard A117.0 (Framing shown for reference only).
2. Make wall access cutout as shown in Figure 6. Be sure that bottom surface is level to the floor and will not protrude below bottom edge of back panel.
3. Attach hanger bracket to wall and level as shown in Figure 5. Using four (4) 5/16" x 2" (51 mm) long bolts and flat washers (not provided). Tighten securely.
4. Install back panel. Place the upper edge of the panel above hanger on the wall. Slide the panel down until it engages the hanger. Be sure back panel is firmly engaged before releasing it.
5. Install rough-in plumbing as shown in Figure 5. Waste lines should extend a minimum of 2" (51 mm) through the back panel. Run supply water inlet lines through back panel. Install service stops (not provided). Turn on supply water and flush thoroughly.
6. Remove bottom access panels from fountain basin and save the screws. Install the fountains to the back panel and wall using four (4) 5/16" x 2" (51 mm) long lag bolts and washers (not provided) for each fountain through holes in back panel. Tighten securely.
7. Cut waste tubes to required length using plumbing hardware and traps (not provided) as a guide. Install hardware and traps. Tighten securely.

8. Make water supply connections from service stop to the fountain Y-strainer. Insert water line to positive stop approximately 3/4" (19 mm) on inlet side of Y-strainer. (See figure 8). Turn on water supply and check for leaks. Newly installed water supply lines should be insulated after leak check is completed.
9. Check stream height from bubbler. Stream height is factory set at 45 - 50 PSI. If supply pressure varies greatly from this, adjust screw on regulator (Item 13). Clockwise adjustment will raise stream height and CCW adjustment will lower stream height. For best adjustment stream height should be approximately 1 1/2" (38 mm) above the bubbler guard. (See Figure 7 and 10 on page 5)
10. **Water Valve Mechanism - ADJUSTMENT PROCEDURE:**
 - Turn adjustment screw (Item #7, figure 7, page 5) "Counter-Clock-wise" until water flow from bubbler starts.
 - Turn adjustment screw "Clockwise" until water flow stops, Then turn an additional 1/2 turn.
11. Replace bottom access panels to fountain basins using screws provided. Tighten securely.

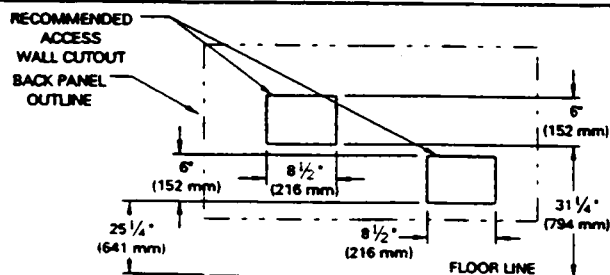

FIG. 6

PUSH BAR MECHANISM

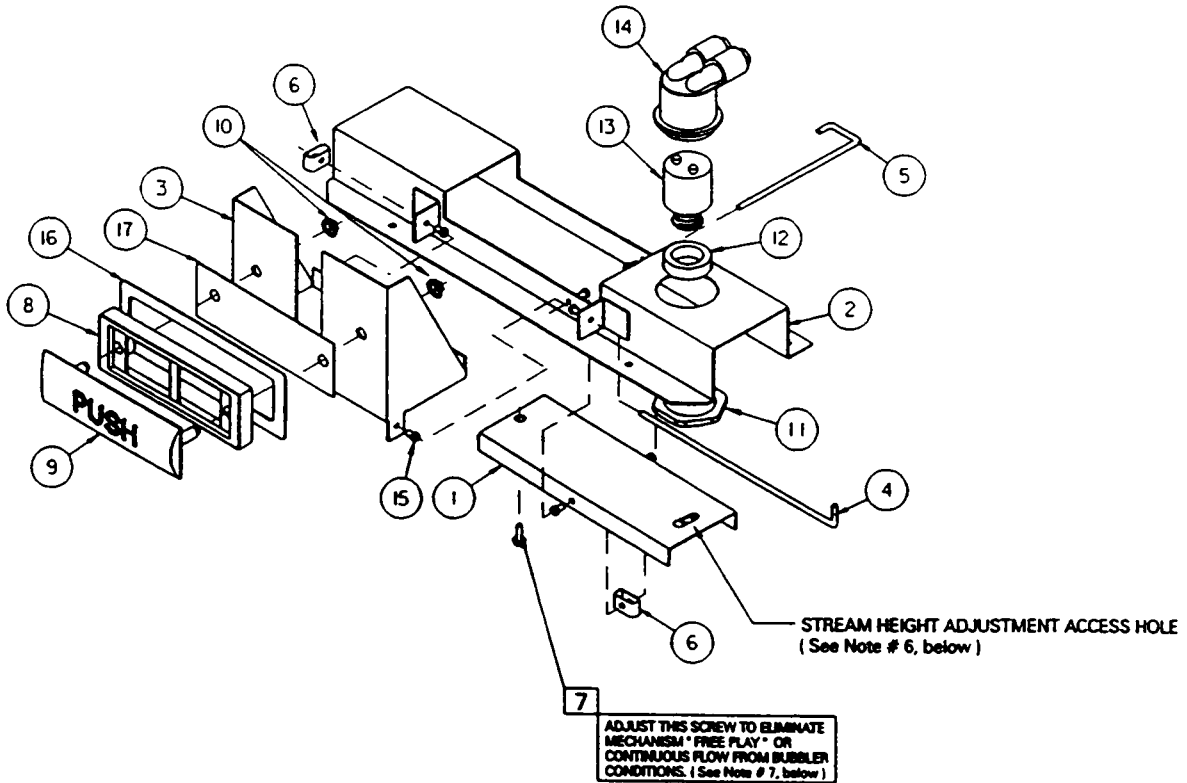

FIG. 7

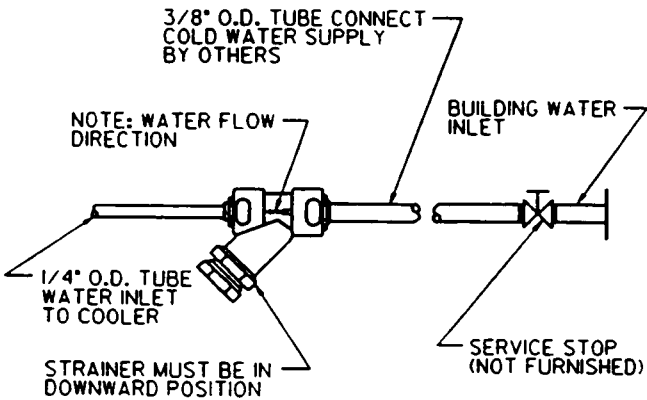

FIG. 8

ITEM NO.	PART NO.	DESCRIPTION
1	26936C	Push Lever Assy
2	26935C	Mounting Bracket Assy
3	26903C	Bracket - Pushbar
4	75517C	Rod - Lever
5	70378C	Rod - Pushbar
6	70283C	Spring Clip
7	70856C	Screw - #10-24 x .38 PHMS
8	55859C	Pushbar - Side & Front
9	101514331640	Insert - Push Bar
10	111411743620	Nut - 1/4, Self Thread
11	40045C	Hex Nut - Reg.
12	10031C	Retaining nut - Reg.
13	61313C	Regulator
14	50985C	Holder - Regulator
15	50198C	Bushing - Snap
16	55899C	Pad - Window Filler
17	27073C	Plate - Backing

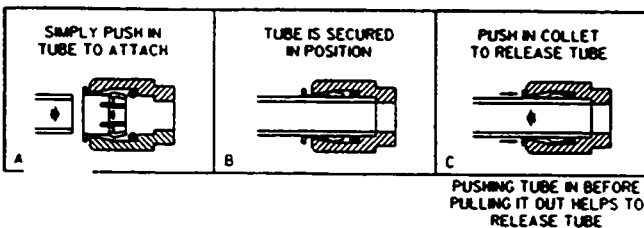

FIG. 9

CORRECT STREAM HEIGHT

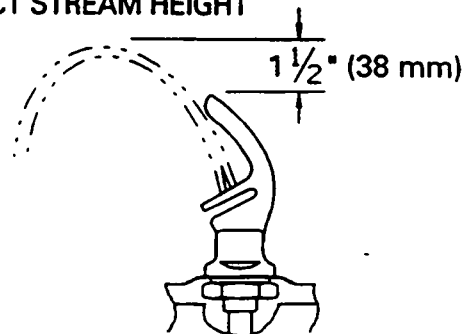
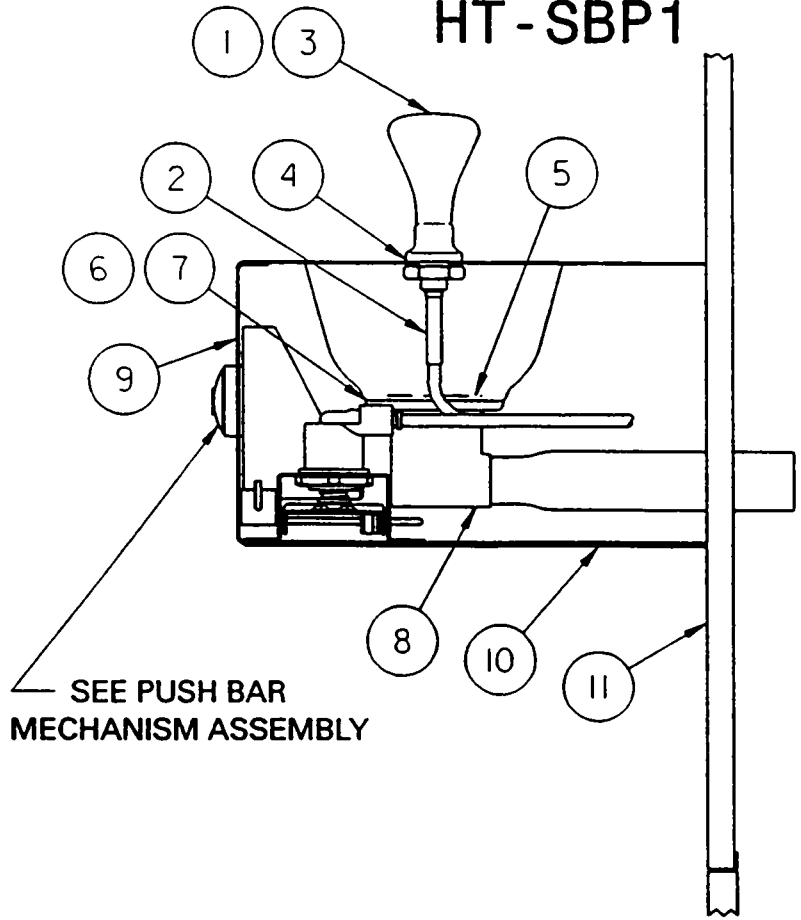
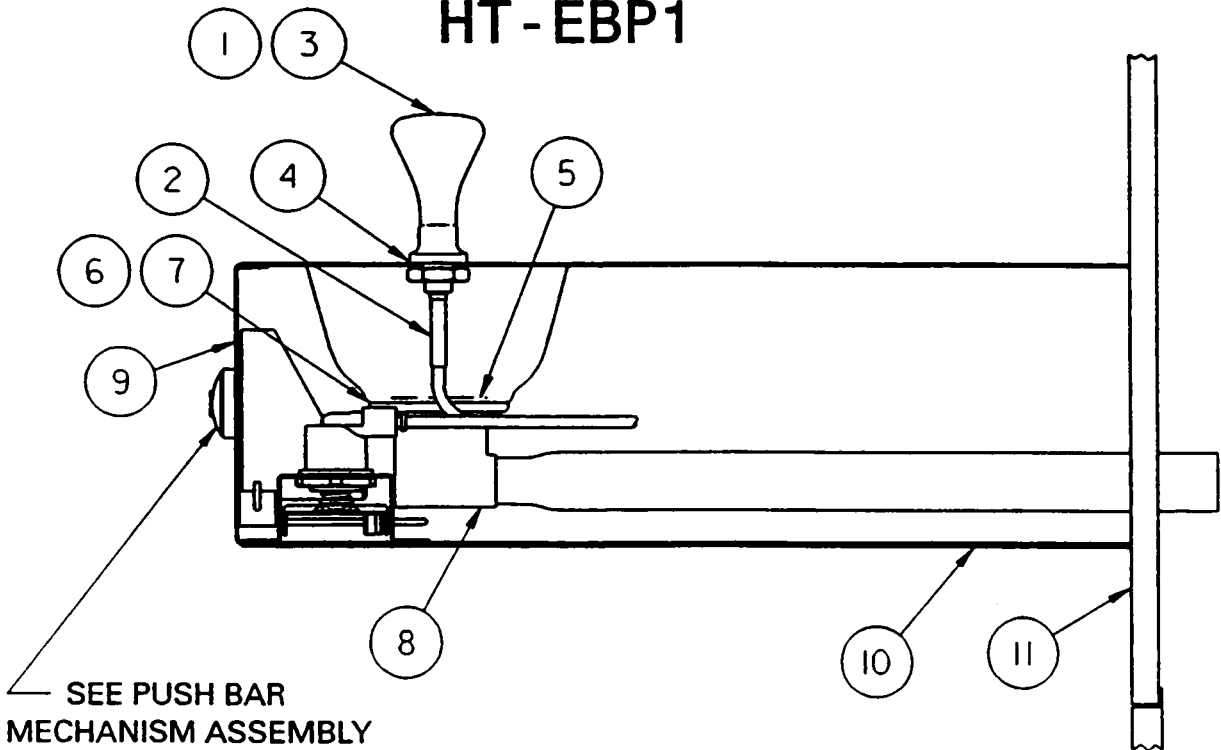

FIG. 10

HT-SBP1



HT-EBP1



ITEMIZED PARTS LIST

ITEM NO.	PART NO.	DESCRIPTION
1	101422831920	Bubbler - Chrome
	101422831450	Bubbler - Golden Bronzetone
2	66318C	Tube Assembly - Bubbler
3	10080C	Nipple - Bubbler (Included with Item No. 2
4	100322740560	Gasket - Bubbler (2 Req'd)
5	160270508640	Strainer Plate - Chrome
	410270508450	Strainer Plate - Golden Bronzetone
6	161637308650	Drain Plug - Chrome
	411637308450	Drain Plug - Golden Bronzetone
7	100147140560	Gasket - Drain
8	601573051550	Waste Line Ass'y (HT-EBP1)
	601573251550	Waste Line Ass'y (HT-SBP1)
9	26868C	Basin - Stainless Steel (HT-EBP1)
	26869C	Basin - Golden Bronzetone (HT-EBP1)
	26870C	Basin - Stainless Steel (HT-SBP1)
	26871C	Basin - Golden Bronzetone (HT-SBP1)
10	23001C	Cover - Bottom (HT-EBP1)
	23002C	Cover - Bottom (HT-SBP1)
11	23193C	Back Panel - Stainless Steel (HT-EBP1)
	23194C	Back Panel - Golden Bronzetone (HT-EBP1)
	23191C	Back Panel - Stainless Steel (HT-SBP)
	23192C	Back Panel - Golden Bronzetone (HT-SBP1)
	26964C	Back Panel - Stainless Steel (HT-SEBP1)
	26965C	Back Panel - Golden Bronzetone (HT-SEBP1)
NOT SHOWN	110711942550	Screw - Truss 8-32 x 3/8
NOT SHOWN	70055C	Nut - Speed
NOT SHOWN	70788C	Y - Strainer (See Page 5, Figure 8)

CAUTION

Cleaning of Golden Bronzitone Models requires special care. Outer surfaces n
be cleaned with a mild detergent or mixture of vinegar and water only, rinsed and
wiped dry. Abrasive and acidic cleaners may eventually damage the Golden
Bronzitone finish.

Halsey Taylor®

P. O. BOX 9001
OAK BROOK, IL 60521
(708) 574-3500

PRINTED IN U.S.A.

FOR PARTS, CONTACT YOUR LOCAL DISTRIBUTOR OR CALL 1-800-323-0620