

Halsey Taylor Owners Manual

Model 7020 and 7030 (Two and Three Station Fountains)

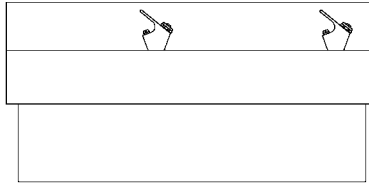

7020 TWO STATION FOUNTAIN

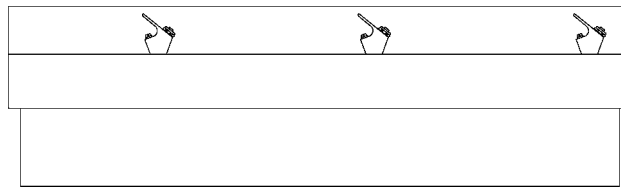

7030 THREE STATION FOUNTAIN

INSTALLER

Halsey Taylor Fountains are among the easiest to install Fountains on the market today. To assure you install these models easily and correctly, **PLEASE READ THESE SIMPLE INSTRUCTIONS BEFORE STARTING THE INSTALLATION. CHECK YOUR INSTALLATION FOR COMPLIANCE WITH PLUMBING, ELECTRICAL, AND OTHER APPLICABLE CODES.** After installation, leave these instructions with the Fountain for future reference.

IMPORTANT

ALL SERVICE TO BE PERFORMED BY AN AUTHORIZED SERVICE PERSON

IMPORTANT! INSTALLER PLEASE NOTE.

THE GROUNDING OF ELECTRICAL EQUIPMENT SUCH AS TELEPHONE, COMPUTERS, ETC. TO WATER LINES IS A COMMON PROCEDURE. THIS GROUNDING MAY BE IN THE BUILDING OR MAY OCCUR AWAY FROM THE BUILDING. THIS GROUNDING CAN CAUSE ELECTRICAL FEEDBACK INTO A FOUNTAIN, CREATING AN ELECTROLYSIS WHICH CAUSES A METALLIC TASTE OR AN INCREASE IN THE METAL CONTENT OF THE WATER. THIS CONDITION IS AVOIDABLE BY USING THE PROPER MATERIALS AS INDICATED. ANY DRAIN FITTINGS PROVIDED BY THE INSTALLER SHOULD BE MADE OF PLASTIC TO ELECTRICALLY ISOLATE THE FOUNTAIN FROM THE BUILDING PLUMBING SYSTEM.

INSTALLATION INSTRUCTIONS

1. Familiarize yourself with the components of the drinking fountain.
2. Determine location of rough-in and plumbing connections. Mount hanger bracket(s) to wall at desired height.
3. Connect plumbing (water tubes) to fountain and bubbler heads. Refer to figure 4 for two-station identification and routing and Figure 8 for three-station identification and routing. Refer to figure 6 for connection of quick connect water fittings.
4. Connect drain tube components and assemble to fountain body. Refer to figure 4 or figure 8 as required.
5. Install fountain to wall. Install additional fasteners to bolt fountain securely to wall.
6. Connect strainer to water supply (service stop). Refer to figure 5. **DO NOT SOLDER TUBES INSERTED INTO THE STRAINER AS DAMAGE TO THE O-RINGS MAY RESULT.** Connect trap to waste stub and fountain.
7. Turn on water supply and check for leaks at all plumbing and drain connections. Fix all leaks as required.

**ROUGH - IN DIMENSIONS
MODEL 7020 (TWO STATION)**

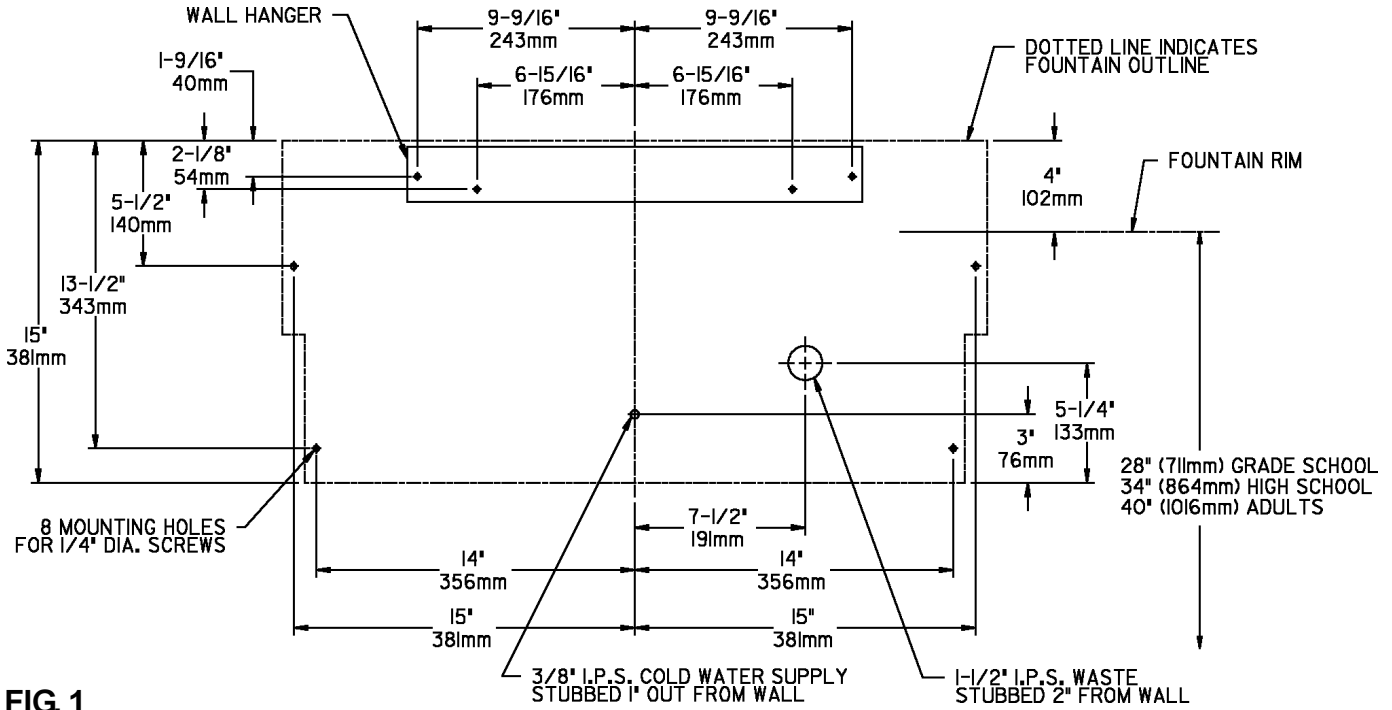

FIG. 1

**ROUGH - IN DIMENSIONS
MODEL 7030 (THREE STATION)**

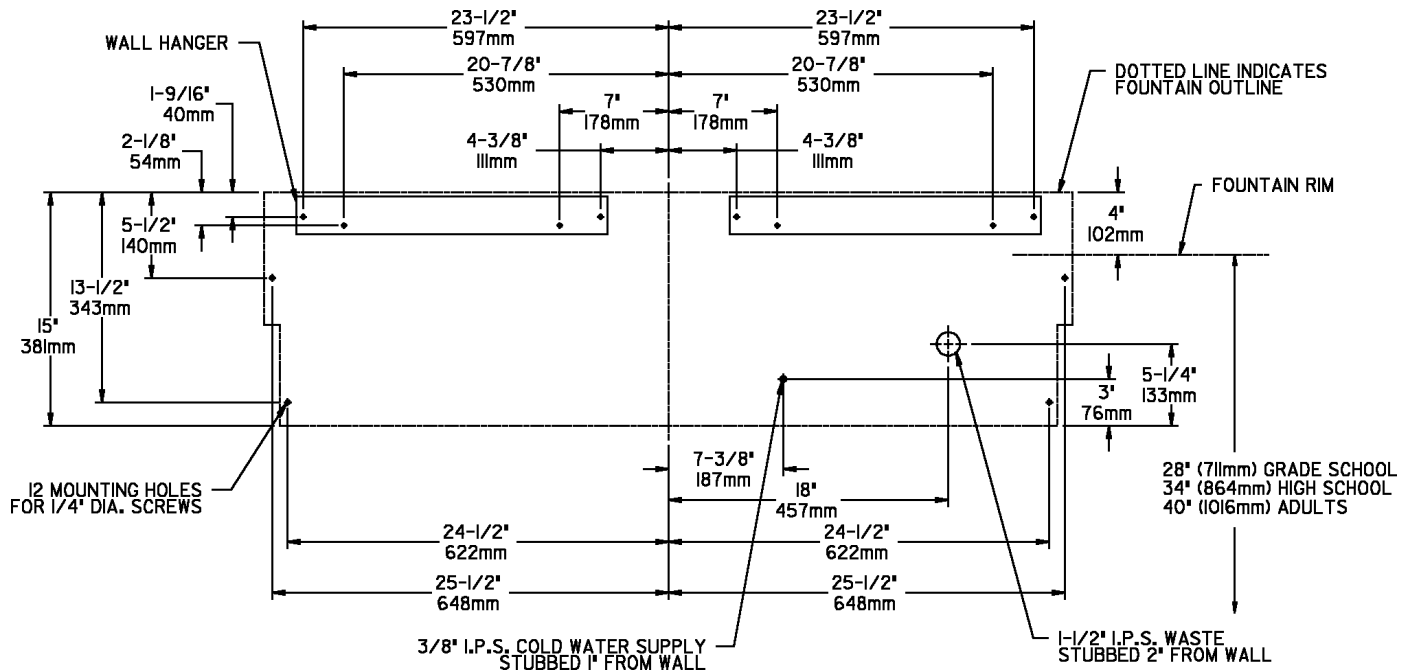
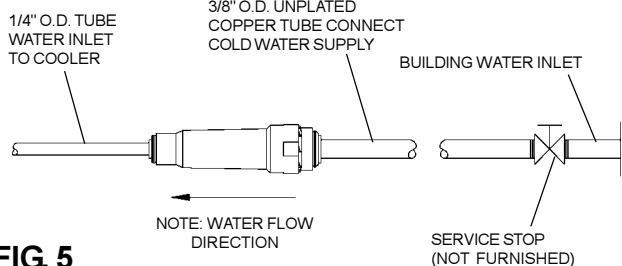
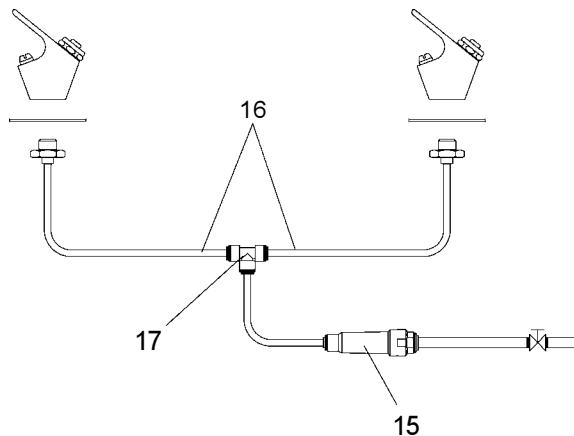
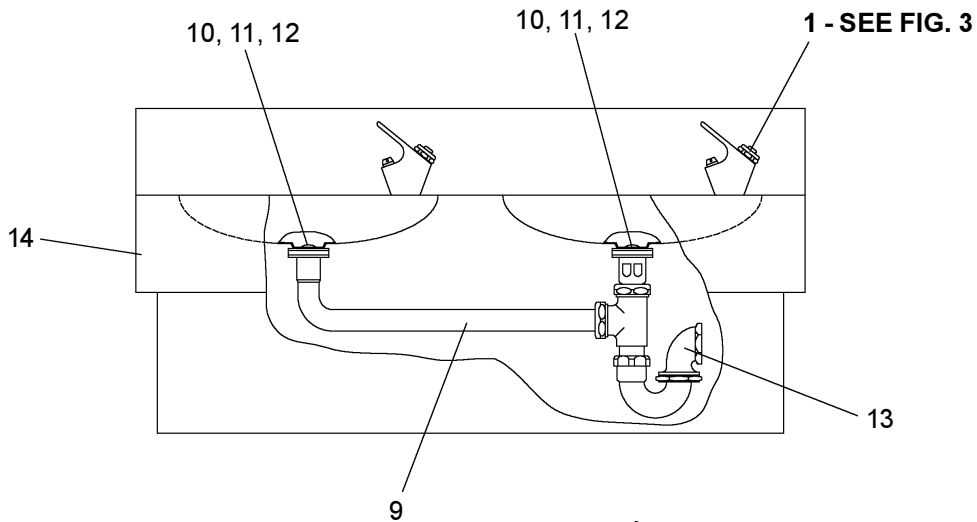
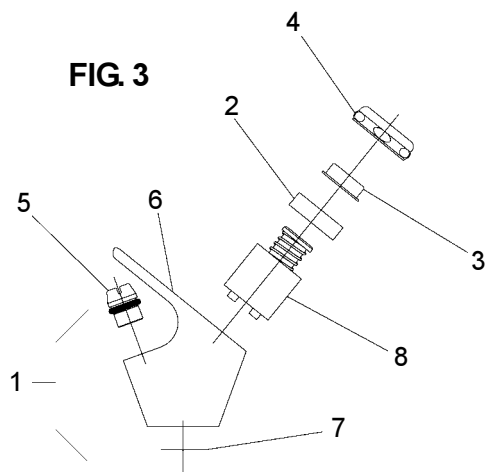

FIG. 2

ITEMIZED PARTS LIST

ITEM NO.	PART NO.	DESCRIPTION
1	45703C	Bubbler Assy.
2	10031C	Retaining Nut
3	40048C	Button
4	40089C	Cover
5	40322C	Orifice Assy.
6	45675C	Bubbler Body
7	60291C	Screen
8	61313C	Regulator
9	LK604	Drain Assy.
10	40038C	Strainer - Beehive
11	40573C	Ferruel - Tailpipe
12	50074C	Gasket - Tailpipe
13	72000986	Elbow - Cast
14	55001009	Fountain
15	55996C	Strainer
16	62301C	Tube Assy.
17	70682C	Tee - 1/4"



OPERATION OF QUICK CONNECT FITTINGS

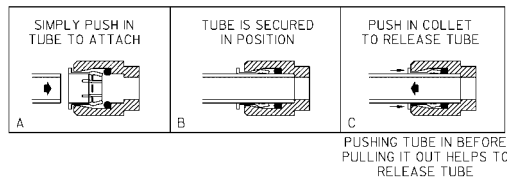

FIG. 5

FIG. 6

7020 / 7030 FOUNTAIN

ITEMIZED PARTS LIST

ITEM NO.	PART NO.	DESCRIPTION
1	45703C	Bubbler Assy.
2	10031C	Retaining Nut
3	40048C	Button
4	40089C	Cover
5	40322C	Orifice Assy.
6	45675C	Bubbler Body
7	60291C	Screen
8	61313C	Regulator
9	LK605	Drain Assy.
10	40038C	Strainer - Beehive
11	40573C	Ferruel - Tailpipe
12	50074C	Gasket - Tailpipe
13	72000986	Elbow - Cast
14	55001010	Fountain
15	55996C	Strainer
16	62301C	Tube Assy.
17	70682C	Tee - 1/4

TROUBLE SHOOTING AND MAINTENANCE

Orifice Assy: Mineral deposits on orifice can cause water flow to spurt or not regulate. Mineral deposits may be removed from the orifice with a small round file or small diameter wire. **CAUTION: DO NOT FILE OR CUT ORIFICE MATERIAL.**

Stream Regulator: If orifice is clean, regulate flow as in "STREAM HEIGHT ADJUSTMENT" instructions below. If replacement is necessary, see parts list for correct regulator part number.

Actuation of Quick Connect Water Fittings: Cooler is provided with lead-free connectors which utilize an o-ring water seal. To remove tubing from the fitting, relieve water pressure, push in on the gray collar while pulling on the tubing (see figure 6).

Stream Height: Stream height is factory set a 45-50 PSI. If supply pressure varies greatly from this, remove items 3 and 4 (see figure 3) and adjust screw on item 8. Clockwise adjustment will raise stream and counter-clockwise adjustment will lower stream. For best adjustment, stream should hit basin approx. 6-1/2" from bubbler.

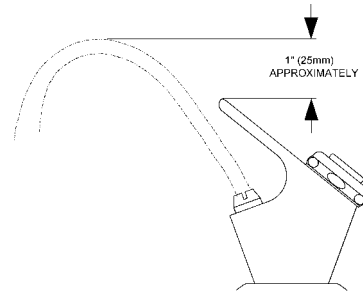

FIG. 7

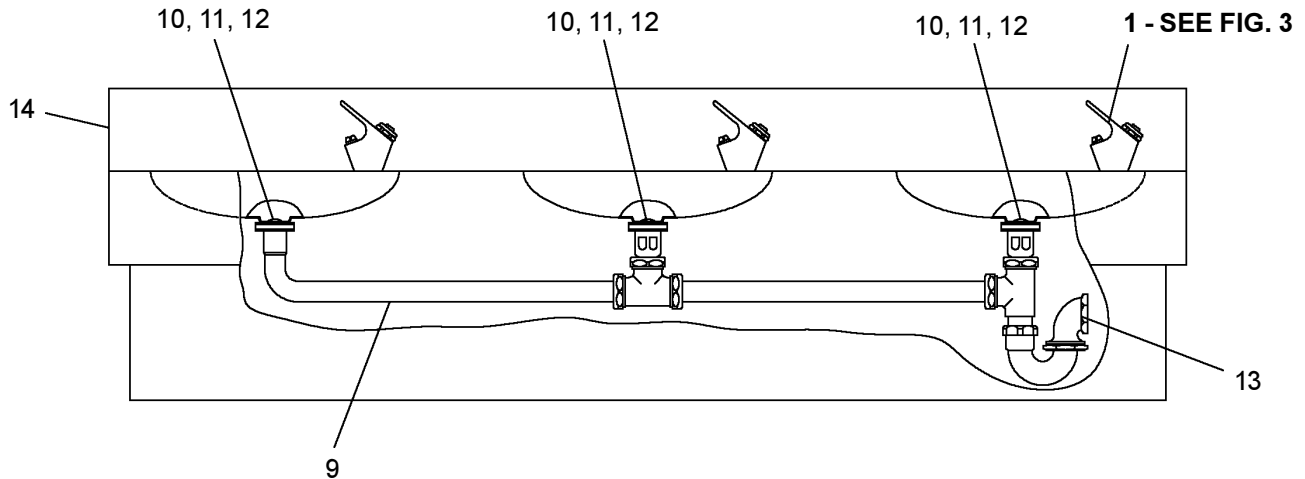
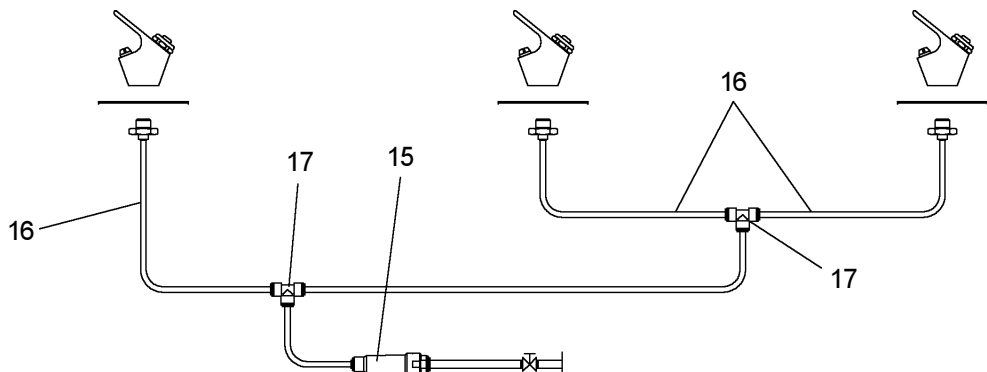

FIG. 8



Halsey Taylor
 2222 CAMDEN COURT
 OAK BROOK, IL 60523
 630.574.3500

PRINTED IN U.S.A.

96471C (Rev. C - 8/00)

FOR PARTS, CONTACT YOUR LOCAL DISTRIBUTOR OR CALL 1.800.323.0620

PAGE 4