

Halsey Taylor Owners Manual

Wall Mount Steel Fountain

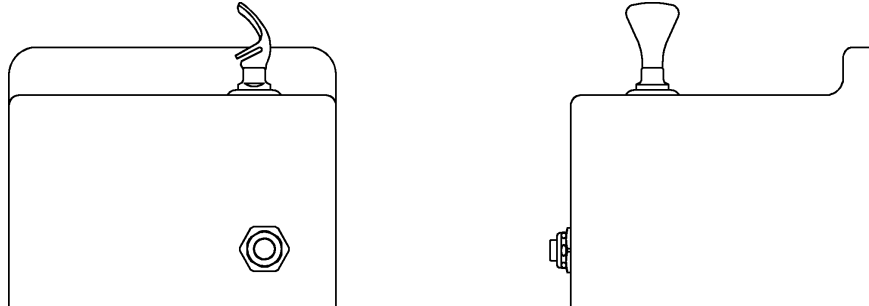

INSTALLER

Halsey Taylor Fountains are among the easiest to install Fountains on the market today. To assure you install these models easily and correctly, **PLEASE READ THESE SIMPLE INSTRUCTIONS BEFORE STARTING THE INSTALLATION. CHECK YOUR INSTALLATION FOR COMPLIANCE WITH PLUMBING, ELECTRICAL, AND OTHER APPLICABLE CODES.** After installation, leave these instructions with the Fountain for future reference.

IMPORTANT

ALL SERVICE TO BE PERFORMED BY AN AUTHORIZED SERVICE PERSON

IMPORTANT! INSTALLER PLEASE NOTE.

THE GROUNDING OF ELECTRICAL EQUIPMENT SUCH AS TELEPHONE, COMPUTERS, ETC. TO WATER LINES IS A COMMON PROCEDURE. THIS GROUNDING MAY BE IN THE BUILDING OR MAY OCCUR AWAY FROM THE BUILDING. THIS GROUNDING CAN CAUSE ELECTRICAL FEEDBACK INTO A FOUNTAIN, CREATING AN ELECTROLYSIS WHICH CAUSES A METALLIC TASTE OR AN INCREASE IN THE METAL CONTENT OF THE WATER. THIS CONDITION IS AVOIDABLE BY USING THE PROPER MATERIALS AS INDICATED. ANY DRAIN FITTINGS PROVIDED BY THE INSTALLER SHOULD BE MADE OF PLASTIC TO ELECTRICALLY ISOLATE THE FOUNTAIN FROM THE BUILDING PLUMBING SYSTEM.

1. Water supply 3/8" O.D. unplated copper tube. Waste 1-1/4" O.D. tube. Contractor to supply waste trap and service stop valve in accordance with local code.
2. Connecting lines to be made of unplated copper and should be thoroughly flushed to remove all foreign matter before being connected to fountain. This fountain is manufactured in such a manner that it does not in any way cause taste, odor, color, or sediment problems.
3. Connect the 3/8" O.D. unplated copper water line from the fountain to the service stop valve. (see Fig.3) **DO NOT SOLDER TUBES INSERTED INTO THE STRAINER AS DAMAGE TO THE O-RINGS MAY RESULT.**
4. These products are designed to operate on 20 psig to 105 psig supply line pressure. If inlet pressure is above 105 psig, a pressure regulator must be installed in the supply line. Any damage caused by reason of connecting this product to supply line pressures lower than 20 psig or higher than 105 psig is not covered by warranty.

ROUGH-IN DIMENSIONS

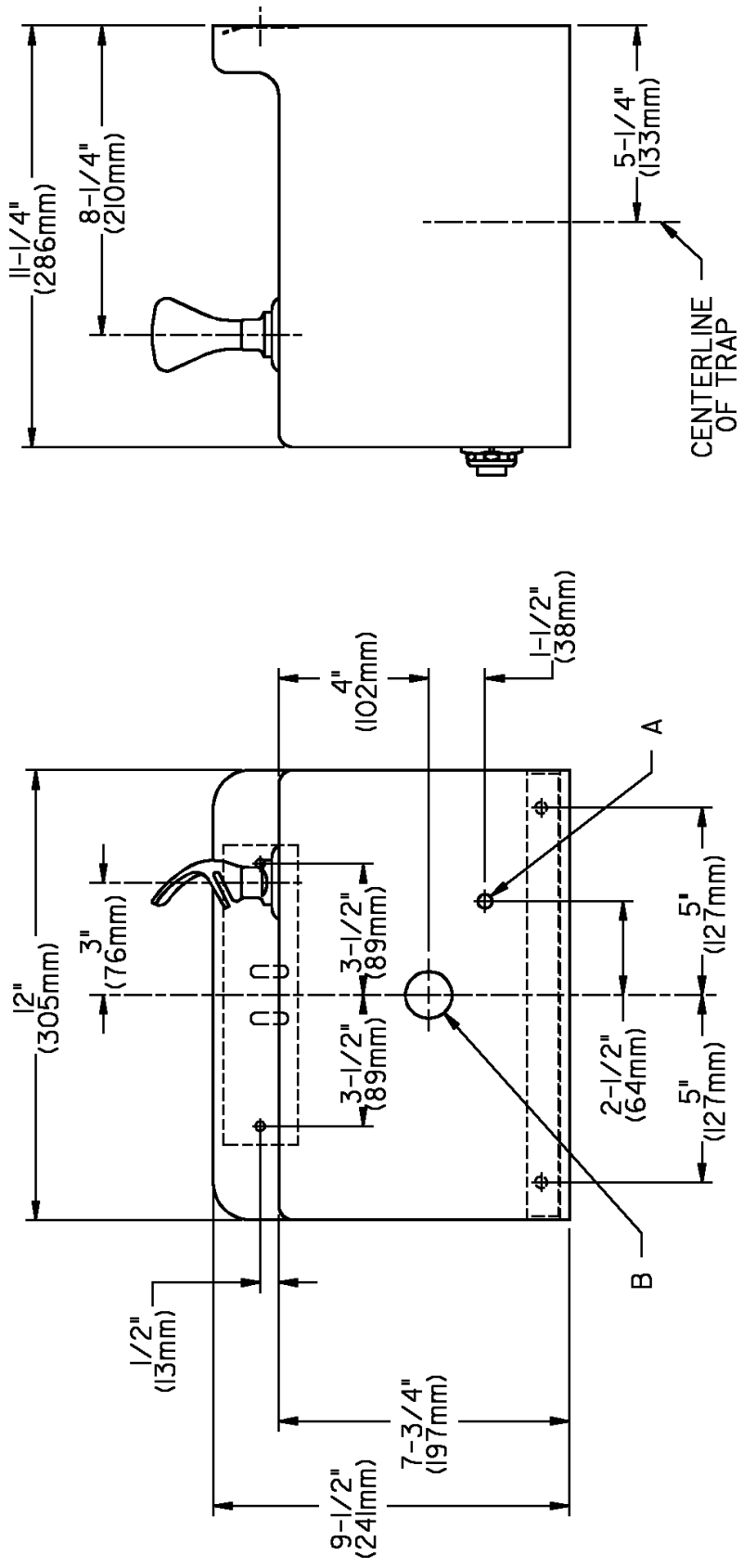

FIG. 1

LEGEND/LEYENDA/LÉGENDE
 A = RECOMMENDED WATER SUPPLY LOCATION 3/8 O.D. UNPLATED COPPER TUBE CONNECT STUB 1-1/2 IN. (38 mm) OUT FROM WALL SHUT OFF BY OTHERS
 SE RECOMIENDA UBICAR EL TUBO CORTO DE CONEXIÓN AL TUBO DE COBRE SIN CHAPAR DE 3/8" DE DIÁM. EXT. A 1-1/2" (38 mm) FUERA DE LA LLAVE DE PASO EN LA PARED COLOCADA POR TERCEROS.
 EMPLACEMENT RECOMMANDÉ D'ALIMENTATION EN EAU PAR TUBE EN CUIVRE NON PLAQUÉ DE 3/8 PO. (9.5 mm) D.E. CONNECTANT UNE TUYAUTERIE DE 1-1/2 PO. (38 mm) DEPUIS LE ROBINET D'ARRÊT FOURNI PAR D'AUTRES.

B = RECOMMENDED LOCATION FOR WASTE OUTLET 1-1/4" O.D. DRAIN
 UBICACIÓN RECOMENDADA PARA EL DRENAJE DE SALIDA DE AGUA DE 1 1/4" DE DIÁMETRO.
 EMPLACEMENT RECOMMANDÉ POUR LE DRAIN DE D.E. 1-1/4" DE SORTIE D'EAU.

START UP INSTRUCTIONS

1. This fountain is to be mounted on a smooth, flat, finished wall surface with adequate support structure.

NOTE: Wall mounting structure must be capable of supporting 300 lb. load on fountain.

2. Establish rim height that fountain is to be mounted at.
3. Refer to rough-in for plumbing.
4. Locate and install trap. (trap not furnished)
5. Install shut-off valve on building water supply. (valve not furnished)
7. Locate and install fountain using 3/8" minimum lag screws or bolts. (screws or bolts not furnished)

CAUTION: This fountain is rated for inlet water pressure of 20-105 PSI. A pressure reducing regulator should be used if the inlet water supply exceeds 105 PSI.

8. Connect water supply and fountain drain.
9. Turn on water supply and check all connections for leaks.

OPERATION OF QUICK CONNECT FITTINGS

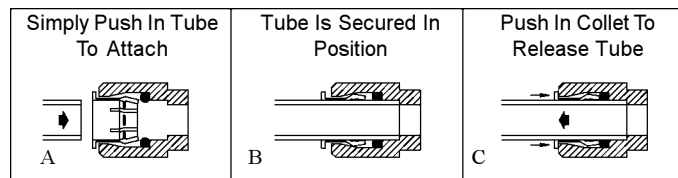

Pushing Tube In Before Pulling It Out Helps To Release Tube.

FIG. 2

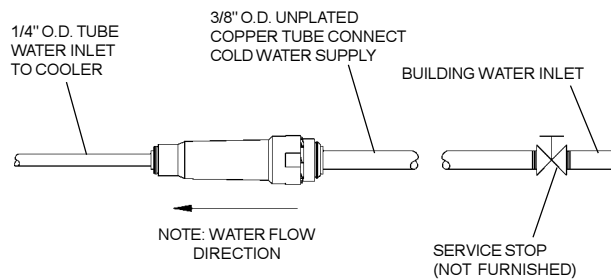
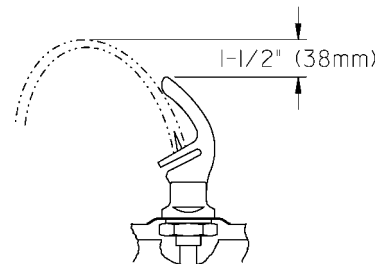

FIG. 3

STREAM HEIGHT ADJUSTMENT: Stream height is factory set at 35 PSI.

If supply pressure varies greatly from this, remove items 1 & 2 (see Fig.5) and adjust screw on item 4. Clockwise adjustment will raise stream and counter-clockwise adjustment will lower stream. For best adjustment, stream should hit basin approx. 6-1/2" from bubbler.



CORRECT STREAM HEIGHT

FIG. 4

5905*B FOUNTAIN

TROUBLE SHOOTING AND MAINTENANCE

ITEMIZED PARTS LIST

ITEM NO.	PART NO.	DESCRIPTION
1	40089C	Cover
2	40048C	Button
3	15005C	Regulator Retaining Nut
4	61313C	Regulator
5	40169C	Hex Nut
6	50986C	Regulator Holder
7	22929C	Basin
8	160270508640	Strainer Plate
9	161637308640	Drain Plug
10	100857140740	Gasket
11	110346220550	Locknut
12	100352940560	Gasket - Slip Nut
13	160356008550	Tailpiece
14	160346308640	Slip Nut
15	100322740560	Bubbler Gasket
16	51546C	Bubbler
17	23046C	Bottom Cover
18	62307C	Bubbler Tube
19	51575C	Ring - Packing
NOT SHOWN	55996C	Strainer

Orifice Assy: Mineral deposits on orifice can cause water flow to spurt or not regulate. Mineral deposits may be removed from the orifice with a small round file not over 1/8" diameter or small diameter wire. **CAUTION: DO NOT** file or cut orifice material.

Stream Regulator: If orifice is clean, regulate flow as in "START UP" instructions on page 3. If replacement is necessary, see parts list for correct regulator part number.

Actuation of Quick Connect Water Fittings: Cooler is provided with lead-free connectors which utilize an o-ring water seal. To remove tubing from the fitting, relieve water pressure, push in on the gray collar while pulling on the tubing.(see Fig.2) To insert tubing, push tube straight into fitting until it reaches a positive stop, approximately 3/4".

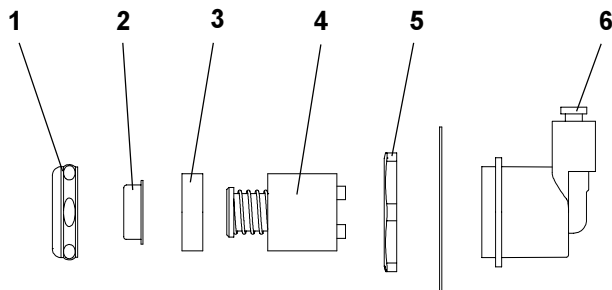
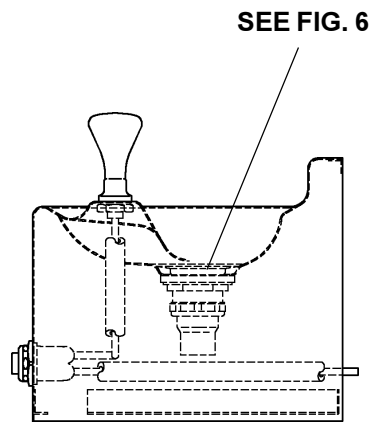
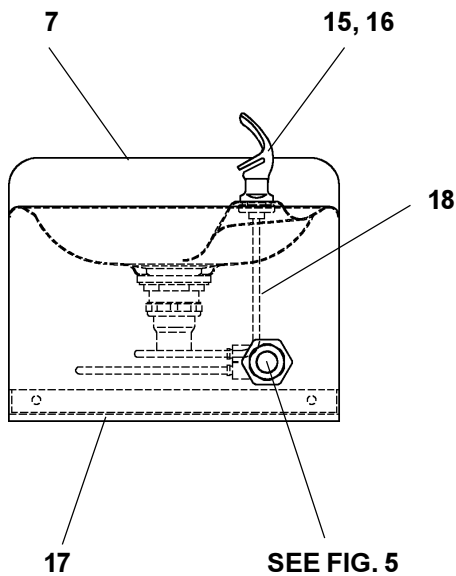

FIG. 5

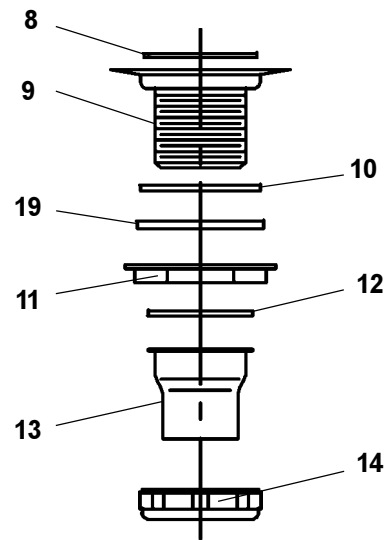

FIG. 6

Halsey Taylor
 2222 CAMDEN COURT
 OAK BROOK, IL 60523
 630.574.3500
 PRINTED IN U.S.A.

FOR PARTS, CONTACT YOUR LOCAL DISTRIBUTOR OR CALL 1.800.323.0620