

Halsey Taylor Owners Manual

Models: 4715FR

Freeze Resistant Floor Mount Steel Fountain

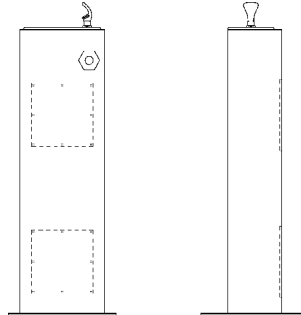

Installer

To assure you install this model easily and correctly, PLEASE READ THESE SIMPLE INSTRUCTIONS BEFORE STARTING THE INSTALLATION. CHECK YOUR INSTALLATION FOR COMPLIANCE WITH PLUMBING ELECTRICAL AND OTHER APPLICABLE CODES. After installation, leave these instructions inside the fountain for future reference.

IMPORTANT

ALL SERVICE TO BE PERFORMED BY AN AUTHORIZED SERVICE PERSON

IMPORTANT! INSTALLER PLEASE NOTE.

THE GROUNDING OF ELECTRICAL EQUIPMENT SUCH AS TELEPHONE, COMPUTERS, ETC. TO WATER LINES IS A COMMON PROCEDURE. THIS GROUNDING MAY BE IN THE BUILDING OR MAY OCCUR AWAY FROM THE BUILDING. THIS GROUNDING CAN CAUSE ELECTRICAL FEEDBACK INTO A FOUNTAIN, CREATING AN ELECTROLYSIS WHICH CAUSES A METALLIC TASTE OR AN INCREASE IN THE METAL CONTENT OF THE WATER. THIS CONDITION IS AVOIDABLE BY USING THE PROPER MATERIALS AS INDICATED. ANY DRAIN FITTINGS PROVIDED BY THE INSTALLER SHOULD BE MADE OF PLASTIC TO ELECTRICALLY ISOLATE THE FOUNTAIN FROM THE BUILDING PLUMBING SYSTEM.

GENERAL INSTALLATION TIPS

1. Be sure to flush the water supply line before you connect it to the inlet fitting on the Freeze Resistant Valve System.
2. There are two drain lines required for this unit. One for the drinking fountain basin drain and one for the valve/water supply line system. The bowl drain is the 3/4" PVC fitting at the bottom of the 6" PVC tube and the valve drains through the small holes in the PVC cap. Provide ample drainage for these two items. It's always better to have too much than not enough.
3. The column (6" PVC tube) must remain vertical. Be sure it remains vertical when backfilling the excavating trench.
4. When the concrete pad, for mounting the fountain, is poured, be sure to allow adequate space around the top of the column so that the flexible cap may be removed for servicing the valve.
5. We recommend that the top of the column be flush or slightly above the top height of the concrete pad.
6. You should test the unit before you backfill. Simply blow on the clear, smaller diameter tubing. A steady stream should flow from the braided tubing line. When air pressure is removed from the clear tubing the water stream should stop.
7. Once you have tested the valve, backfilled the hole, and poured the concrete mounting pad, you are ready to set the fountain. After bolting the fountain in place remove the access panels and connect the air control valve tubing, supply water tubing, and drain lines. Excess lengths of tubing should be trimmed. Be careful not to kink, twist, or damage the tubes. The water supply line must have a straight run from the basin bubbler down to the control valve. If a straight run is not maintained, water will become trapped and freeze, leaving the unit inoperable. Test the fountain again. If it fails to work, the air control line may be kinked or connected improperly. Be sure to keep water out of the air control line.
8. These products are designed to operate on 20 psig to 105 psig supply line pressure. If inlet pressure is above 105 psig, a pressure regulator must be installed in the supply line. Any damage caused by reason of connecting this product to supply line pressures lower than 20 psig or higher than 105 psig is not covered by warranty.

Important: Do not pull up on lines coming out of the PVC column. This raises the water valve above the frost line with disastrous results.

4715FR ROUGH-IN

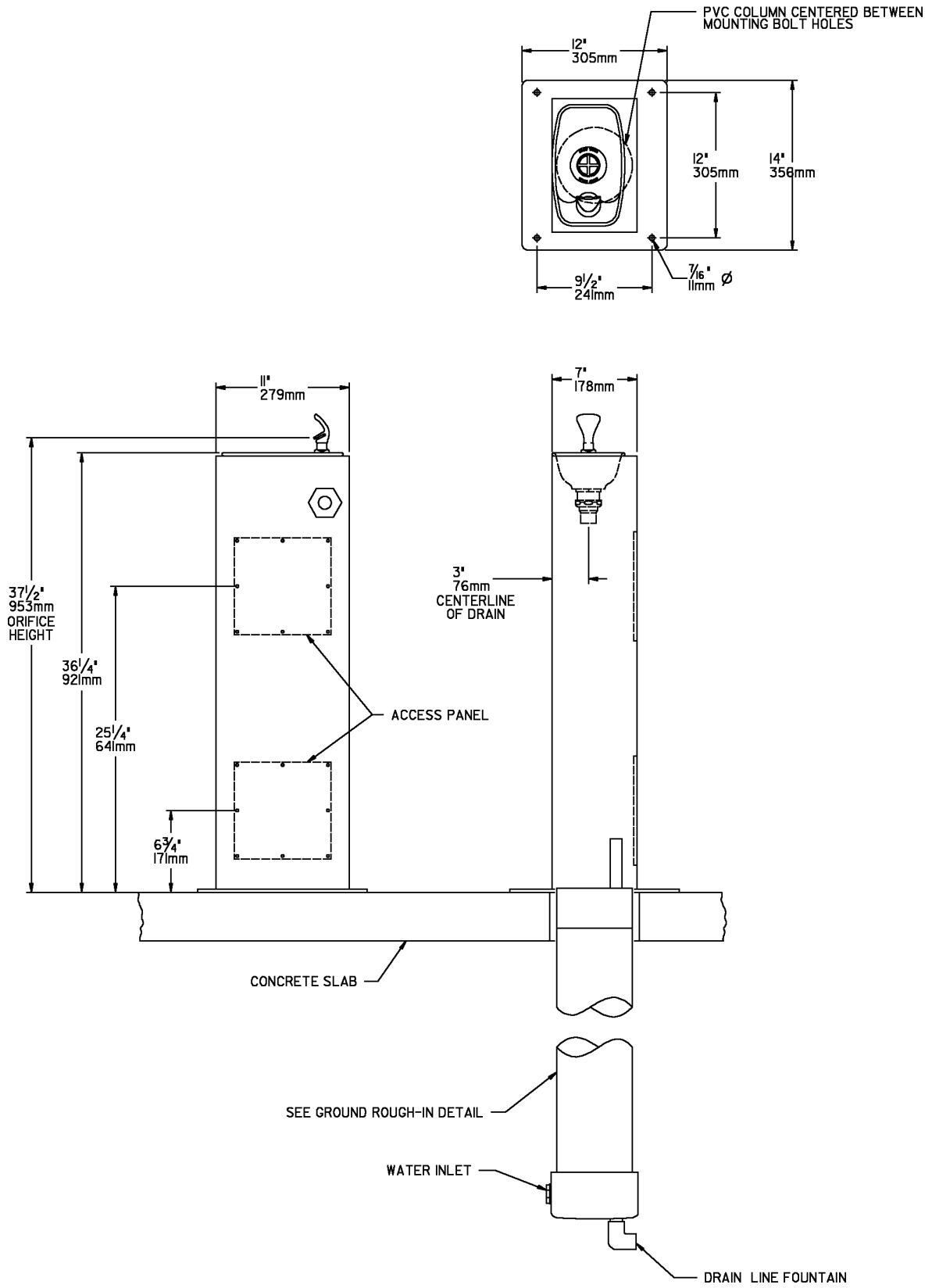

INSTALLATION INSTRUCTIONS

1. **Prepare trench for water supply and waste drain lines** (if required by local codes). The hole should be deep enough to accommodate the PVC column and 5 cubic feet of porous fill (large broken rock). Additional porous fill may be required due to local ground conditions. (See Ground Rough-In Detail Page 4)
2. **Lay drain lines and water supply lines.** Provide service shut off valve for maintenance. Flush the water supply line before attaching to the shut off valve.
3. **Set PVC column in excavating pit.** Connect the water supply line to the inlet on the PVC column. Remove valve assembly from the PVC column by carefully pulling up on the connecting tubing. Pressure test the valve assembly for leaks. Check operation of the water valve by blowing on the small clear diameter tubing. A steady stream of water should flow from the braided tubing. After releasing air pressure from the small clear tubing the water stream should stop.
4. **Replace the water valve into the PVC column.** Make sure the supply hose coils into the bottom of the PVC column without any kinks. Cap the PVC column. Protect the ends of the connecting tubes and backfill the trench. Keep the PVC column vertical at all times.
5. **Form the concrete mounting pad and locate the fountain anchor bolts** in the proper position. (Refer to Rough-In for correct location of anchor bolts.) Pour concrete and finish. Be sure to keep concrete away from the top of the PVC column to allow removal of PVC cap to allow for future service. Let concrete set 24 hours minimum before mounting fountain.
6. **Double check that the water valve is positioned fully** at the bottom of the PVC column. Install insulation into the PVC column and push down onto the top of the water valve.
7. **Mount the fountain** onto the anchor bolts. Level and shim fountain as required.
8. **Remove access panels** from the fountain. Connect the drain line, water line and air control lines. Excess lengths should be trimmed from the tubing. The water supply line must be positioned for positive drain back out of the fountain and down through the PVC column to the water valve. **Any water allowed to be trapped above the frost line will freeze leaving the unit inoperable.** Do not pull up on the connection lines as this could raise the valve above the frost line.
9. **Check for proper operation** by using fountain push button(s). If the valve does not work properly check for leaks or kinks in the air control line.
10. **Replace access panels** after insuring proper operation. Installation of your fountain is now complete.

PARTS LIST		
ITEM NO.	PARTNO.	DESCRIPTION
1	100147140560	Gasket - Drain
2	100322740560	Bubbler Gasket
3	100352940560	Gasket
4	160270508640	Strainer Plate
5	110346220550	Locknut 1-1/2"
6	160346308640	Slipnut
7	160356008550	Tailpiece 1-1/4" O.D.
8	170705042830	Basin
9	45671C	Valve System Control
10	45674C	Bubbler
11	600985551640	Drain Plug
12	110544942550	Set Screw #8-32 x 1/8"
NS	66275C	Tube Assy - Bubbler

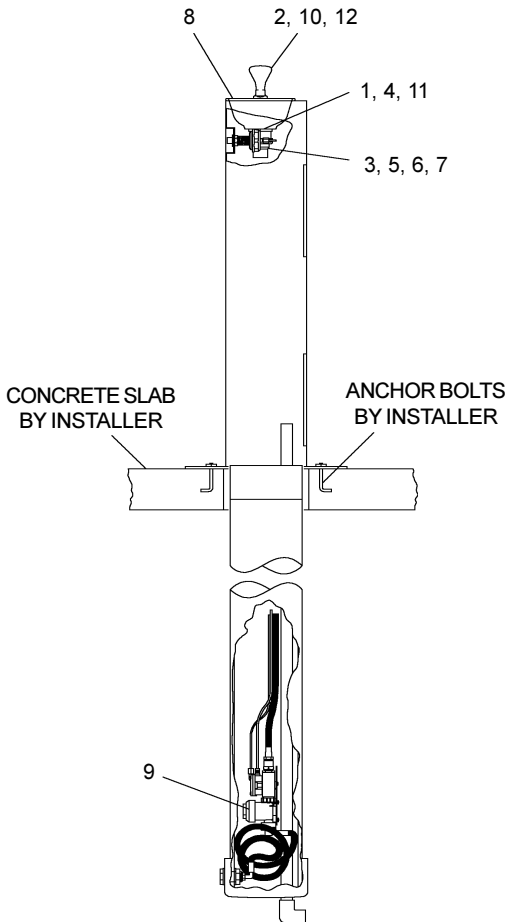

TROUBLE SHOOTING AND MAINTENANCE

Insufficient Bubbler Flow: Check that the shut-off valve is wide open. Verify minimum 20 PSI supply pressure. Clean inlet strainer screen located in the valve body. Clean rubber orifice in flow control located below frost line in bushing between barb fitting and valve.

No Flow: Check for leaks in the air tubing going from the push button to the valve. Make sure the air tubing compression nuts are hand tight. Disconnect air tube from push button assembly. Blow into tube to verify valve function. Replace if necessary. Disconnect air tube from push button. Place finger over air outlet. Push button to test diaphragm. Tighten diaphragm cap screws. Replace diaphragm if necessary.

Continued Insufficient or Varied Height of Bubbler Flow: Replace flow control. Check for kinks in the tubing.

Continuous Bubbler Flow: Insure that push button is not obstructed and springs back to normal position. Remove four screws which secure plastic diaphragm block to valve body. Pull plastic and rubber diaphragm assembly out of valve body. Locate tiny hole in rubber diaphragm just under lip of plastic part. Clean debris from this hole. Inspect valve seat for grooves. If seat is worn, replace with stainless steel seat (Newer Models) or replace valve (Older Models, Integral Brass Seat). If valve seat was OK and diaphragm holes were free from debris, inspect rubber button located at center of floating steel disc in valve diaphragm block assembly. If button is worn, turn disc over or replace it. If diaphragm and seats are good condition, stretch spring slightly. Spring is located behind floating stainless steel plate. Insure that air bleed port on valve plastic block assembly is not plugged.

Ground Rough-In Detail

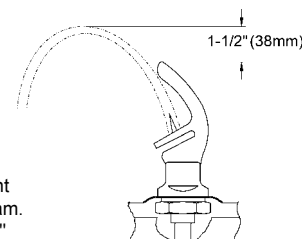
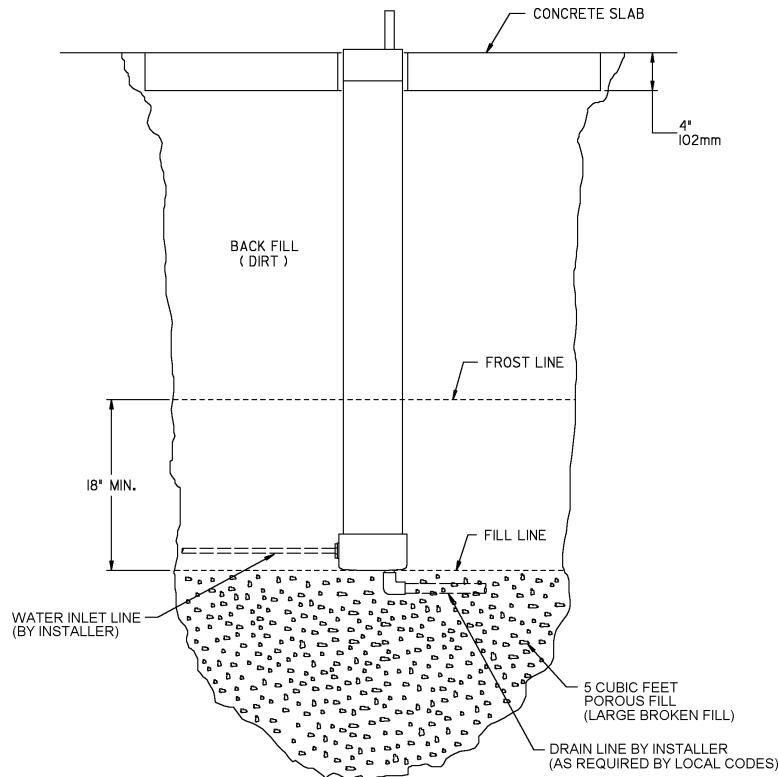

STREAM HEIGHT ADJUSTMENT:

Stream height is factory set at 35 PSI. If supply pressure varies greatly from this, adjust screw on regulator. Clockwise adjustment will raise stream and counter-clockwise adjustment will lower stream. For best adjustment, stream should hit basin approximately 6-1/2" from the bubbler.

Halsey Taylor
2222 CAMDEN COURT
OAK BROOK, IL 60523
630.574.3500

PRINTED IN U.S.A.

FOR PARTS, CONTACT YOUR LOCAL DISTRIBUTOR OR CALL 1.800.323.0620