

Halsey Taylor Owners Manual

4410 Freeze Resistant Tubular Fountain

STOP!

PLEASE READ THE FOLLOWING INFORMATION.

- **INSTALLATION INSTRUCTIONS FOR THE 4410FR FTN. WITH 97243C SINGLE VALVE CONTROL ASSEMBLY ARE LOCATED ON PAGES 2 - 5.**
- **INSTALLATION INSTRUCTIONS FOR THE 4410FR FTN. WITH SANITARYFR1 VALVE ARE LOCATED ON PAGES 6 - 12.**

INSTALLER

Halsey Taylor Fountains are among the easiest to install Fountains on the market today. To assure you install these models easily and correctly, PLEASE READ THESE SIMPLE INSTRUCTIONS BEFORE STARTING THE INSTALLATION. CHECK YOUR INSTALLATION FOR COMPLIANCE WITH PLUMBING, ELECTRICAL, AND OTHER APPLICABLE CODES. After installation, leave these instructions with the Fountain for future reference.

IMPORTANT

THE GROUNDING OF ELECTRICAL EQUIPMENT SUCH AS TELEPHONE, COMPUTERS, ETC. TO WATER LINES IS A COMMON PROCEDURE. THIS GROUNDING MAY BE IN THE BUILDING OR MAY OCCUR AWAY FROM THE BUILDING. THIS GROUNDING CAN CAUSE ELECTRICAL FEEDBACK INTO A FOUNTAIN, CREATING AN ELECTROLYSIS WHICH CAUSES A METALLIC TASTE OR AN INCREASE IN THE METAL CONTENT OF THE WATER. THIS CONDITION IS AVOIDABLE BY USING THE PROPER MATERIALS AS INDICATED. ANY DRAIN FITTINGS PROVIDED BY THE INSTALLER SHOULD BE MADE OF PLASTIC TO ELECTRICALLY ISOLATE THE FOUNTAIN FROM THE BUILDING PLUMBING SYSTEM.

IMPORTANT

ALL SERVICE TO BE PERFORMED BY AN AUTHORIZED SERVICE PERSON

Halsey Taylor Owners Manual

4410 Freeze Resistant Tubular Fountain with 97243C Single Valve Control Assembly

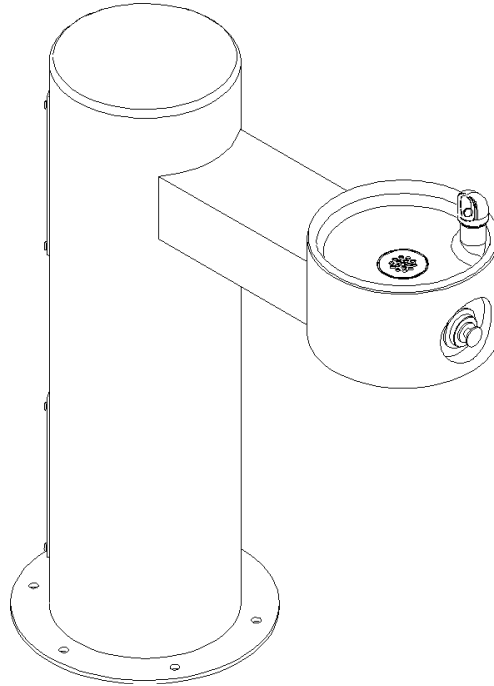

IMPORTANT! INSTALLER PLEASE NOTE

Do not pull up on lines coming out of the PVC column. This raises the water valve above the frost line with disastrous results.

General Installation Tips

1. Be sure to flush water supply line before you connect it to the inlet fitting on Freeze Resistant Valve System.
2. There are two drain lines required for this unit. One for the drinking fountain basin drain and one for the valve/water supply line system. The bowl drain is the 3/4" PVC fitting at the bottom of the 6" PVC tube and the valve drains through the small holes in the PVC cap. Provide ample drainage for these two items. It's always better to have too much than not enough.
3. The column (6" PVC tube) must remain vertical. Be sure it remains vertical when backfilling the excavating trench.
4. When the concrete pad, for mounting the fountain, is poured, be sure to allow adequate space around the top of the column so that the flexible cap may be removed for servicing the valve.
5. We recommend that the top of the column be flush or slightly above the top height of the concrete pad.
6. You should test the unit before you backfill. Simply blow on the clear, small diameter tubing. A steady stream should flow from the braided tubing line. When air pressure is removed from the clear tubing the water stream should stop.
7. Once you have tested the valve, backfilled the hole and poured the concrete mounting pad you are ready to set the fountain. After bolting the fountain in place connect the air control valve tubing, supply water tubing and drain lines. The water supply line must have a straight run from the basin bubbler down to the control valve. If a straight run is not maintained water will become trapped and freeze leaving the unit inoperable. Test the fountain again. If it fails to work, the air control line may be kinked or connected improperly. Be sure to keep water out of the air control line.
8. These products are designed to operate on 20 psig to 105 psig supply line pressure. If inlet pressure above 105 psig, a pressure regulator must be installed in the supply line. Any damage caused by reason of connecting this product to supply line pressure lower than 20 psig or higher than 105 psig is not covered by warranty.

**SITE PREPARATION DETAIL FOR THE
4410FR FTN. WHEN USING 97243C SINGLE VALVE CONTROL ASSY.**

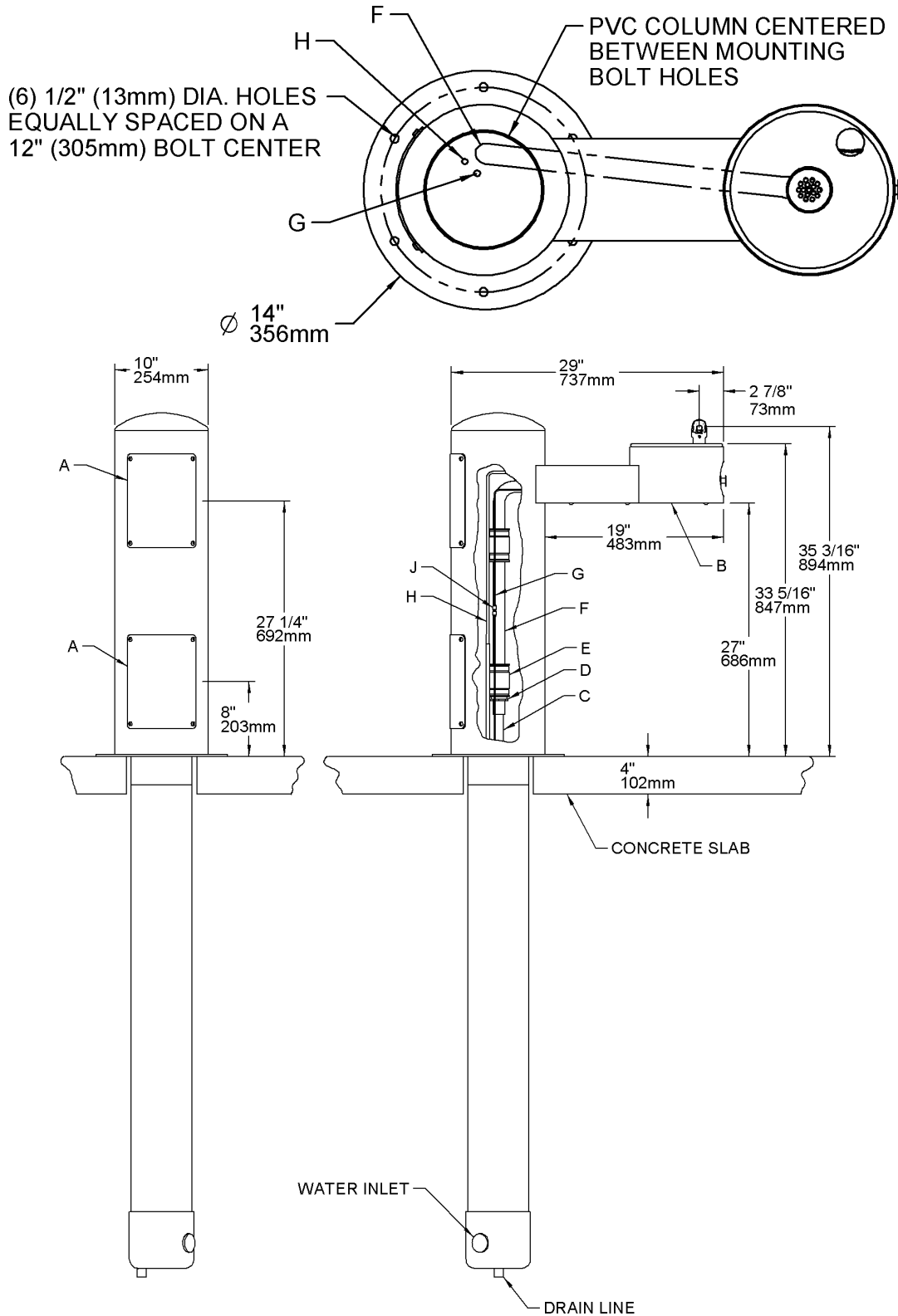

LEGEND

A = ACCESS PANEL (8" X 10")

B = REMOVABLE BOTTOM COVER

C = 1" PVC DRAIN

D = PRESSURE FITTING 1-1/4" x 3/4"

E = CONNECTOR 1-1/4" TO 1-1/4"

F = 1-1/4" DRAIN TUBE

G = AIR CONTROL LINE

H = 1/4" WATER LINE

J = CONNECTOR FOR AIR CONTROL LINE

FIG. 1

INSTALLATION INSTRUCTIONS FOR INSTALLING 97243C SINGLE VALVE CONTROL ASSY.

1. Prepare trench for water supply and waste drain lines (if required by local codes). The hole should be deep enough to accommodate the PVC column and 5 cubic feet of porous fill (large broken rock). Additional porous fill may be required due to local ground conditions. (See Site Preparation Detail below).
2. Lay drain lines and water supply lines. Provide service shut off valve for maintenance. Flush the water supply line before attaching to the shut off valve.
3. Set PVC column in excavating pit. Connect the water supply line to the inlet on the PVC column. Remove valve assembly from the PVC column by carefully pulling up on the connecting tubing. Pressure test the valve assembly for leaks. Check operation of the water valve by blowing on the small clear diameter tubing. A steady stream of water should flow from the braided tubing. After releasing air pressure from the small clear tubing the water stream should stop.
4. Replace the water valve into the PVC column. Make sure the supply hose coils into the bottom of the PVC column without any kinks. Cap the PVC column, protect the ends of the connecting tubes and backfill the trench. Keep the PVC column vertical at all times.
5. Form the concrete mounting pad and locate the fountain anchor bolts in the proper position. (Refer to Rough-in for correct location of anchor bolts.) Pour concrete and finish. Be sure to keep concrete away from the top of the PVC column to allow removal of PVC cap to allow for future service. Let concrete set 24 hours minimum before mounting fountain.
6. Double check that the water valve is positioned fully at the bottom of the PVC column. Install insulation into the PVC column and push down onto the top of the water valve.
7. Mount the fountain onto the anchor bolts. Level and shim fountain as required.
8. Connect the drain line, water line and air control lines. Excess lengths should be trimmed from the tubing. The water supply line must be positioned for positive drain back out of the fountain and down through the water valve. **Any water allowed to be trapped above the frost line will freeze leaving the unit inoperable.** Do not pull up on the connection lines as this could raise the valve above the frost line.
9. Check for proper operation by using fountain push button. If the valve does not work properly check for leaks or kinks in the air control line.
10. After insuring proper operation reassemble fountain. Installation of your fountain is now complete.

**SITE PREPARATION DETAIL
FIG. 2**

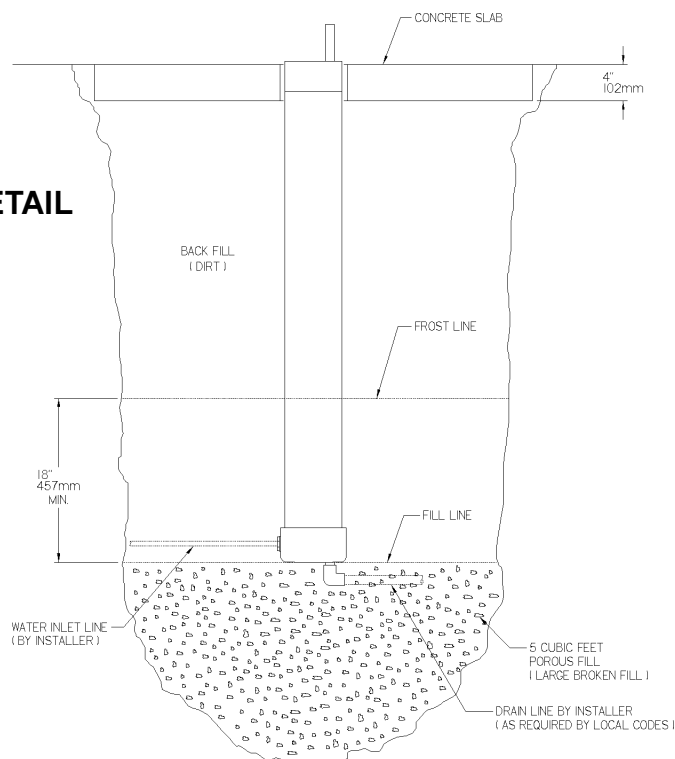

TROUBLE SHOOTING

Insufficient Bubbler Flow: Check that the shut-off valve is wide open. Verify minimum 20 PSI supply pressure. Clean inlet strainer screen located in the valve body. Clean rubber orifice in flow control located below frost line in bushing between barb fitting and valve.

No Flow: Check for leaks in the air tubing going from the push button to the valve. Make sure the air tubing compression nut is hand tight. Disconnect air tube from push button. Place finger over air outlet. Push button to test diaphragm. Tighten diaphragm cap screws. Replace diaphragm if necessary.

Continued Insufficient or Varied Height of Bubbler Flow:

- Replace flow control.
- Check for kinks in the tubing.
- Remove the PVC cap from the PVC column. Remove the valve assembly from the PVC column by carefully pulling up on the connecting tubing. Pressure test the valve assembly for leaks. Check stream height from the bubbler. Stream height is factory set at 35 PSI. If supply pressure varies greatly from this, adjust the screw on the regulator (Item 20, Page 5, Stream Height Adjustment Detail). Clockwise adjustment will raise stream and counter-clockwise adjustment will lower stream. For best adjustment stream height should be approx. 1-1/2" (38mm) above the bubbler guard. Replace the valve into the PVC column. Make sure the supply hose coils into the bottom of the PVC column without any kinks and double check that the valve is positioned fully at the bottom of the PVC column. Cap the PVC column.

Continuous Bubbler Flow: Insure that push button is not obstructed and springs back to normal position. Remove four screws which secure plastic diaphragm block to valve body. Pull plastic and rubber diaphragm assembly out of valve body. Locate tiny hole in rubber diaphragm just under lip of plastic part. Clean debris from this hole. Inspect valve seat for grooves. If valve seat was OK and diaphragm hole was free from debris, inspect rubber button located at center of floating steel disc in valve diaphragm block assembly. If button is worn, turn disc over or replace it. If diaphragm and seats are in good condition, stretch spring slightly. Spring is located behind floating stainless steel plate. Insure that air bleed port on valve plastic block assembly is not plugged.

The following items are included with the 4410FR Fountain

PARTS LIST		
ITEM NO.	PART NO.	DESCRIPTION
1	100147140560	Drain Gasket
2	75589C	Gasket
3	101449542550	Clamp - Hose
4	101570540560	Drain Gasket
5	15009C	Nipple Assy. - Bubbler
6	15014C	Retaining Nut
7	40045C	Hex Nut 1-5/16"
8	45392C	Bubbler
9	45403C	Push Button Actuator
10	75588C	Slip Joint Nut 1-1/4"
11	45464C	Drain Plug 1-1/2"
12	45824C	Fountain Body
13	45832C	Access Panel
14	45663C	Push Button Sleeve
15	45483C	Drain Tube
16	45833C	Bottom Cover
17	50986C	Regulator Holder
18	56121C	Drain Elbow 1-1/4"
19	56082C	Regulator Nut
20	61313C	Regulator
21	66346C	Drain Tube
22	66461C	Fitting 1/14" x 1-1/4"
23	66719C	Tube Assembly
24	28467C	Basin
25	75535C	Pinned Torx Screw 1/4-20 x .75"
26	100322740560	Washer
27	97243C	Single Control Valve System Complete
*28	45787C	Single Control Valve Assy.
29	45788C	Rainbird Check Valve
30	45789C	Acorn Valve Assy.
31	45790C	Flow Control Fitting
32	55960C	Pressure Fitting 1-1/4" To 3/4"
33	75565C	Fitting - Double Male Connector
NS	75521C	Bit - Pinned Torx T-27
NS	75596C	Paint Touch-up (Pen)
NS	56092C	Poly Tubing - 1/4" (Cut To Length) - To Bubbler
NS	56123C	Poly Tubing - 1/8" (Cut To Length) - To Actuator
NS	28091C	Nameplate Insert

*Includes items 29, 30, 31

Touch-up Paint

For minor scratches a Touch-up Paint Stick is available. For repairing large defects, off-the-shelf aerosol paint from your local hardware store can be used. Listed are two suggested brandnames.

- Brandname: X-O
XO-11 Hunter Green
- Brandname: Ace Hardware
Rust Stop / Machine & Implement International Green

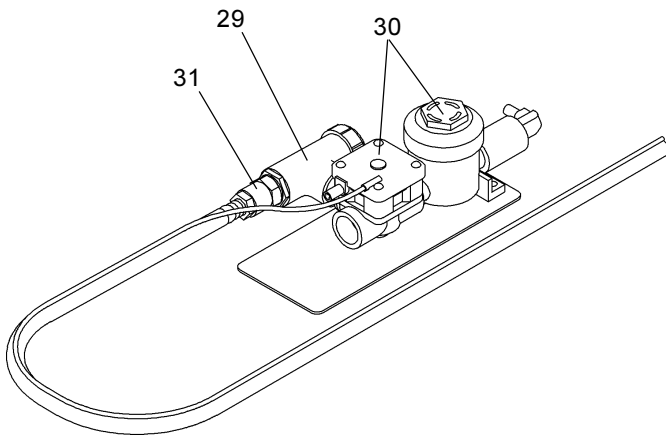

Single Valve Assy. (Item 28)

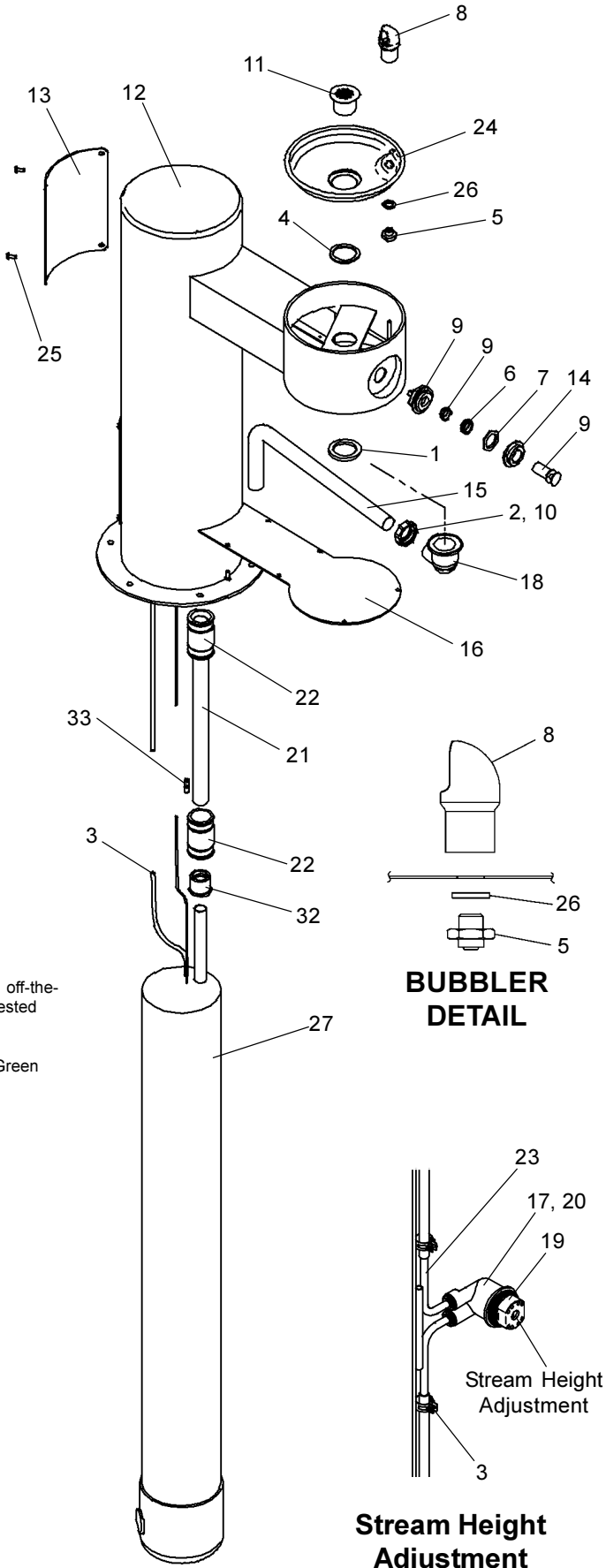

FIG. 3

Stream Height Adjustment Detail

Halsey Taylor

2222 CAMDEN COURT
OAKBROOK, IL 60523
630.574.3500

PRINTED IN U.S.A.

FOR PARTS, CONTACT YOUR LOCAL DISTRIBUTOR OR CALL 1.800.323.0620

Halsey Taylor Owners Manual

4410 Freeze Resistant Tubular Fountain with SanitaryFR1 Valve

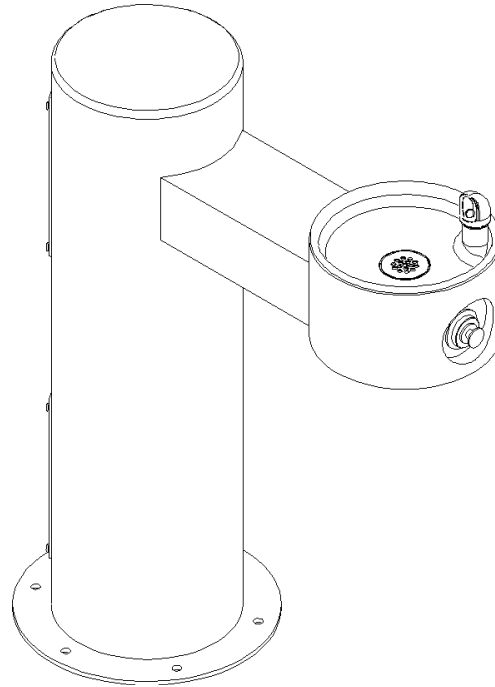

IMPORTANT! INSTALLER PLEASE NOTE

Tubing must be cut to the right length. Do not coil any excess tubing or it will cause valve to malfunction.

General Installation Tips

1. Prepare trench for water supply and waste drain lines. The hole should be deep enough to accommodate the PVC column. Additional porous fill and drain pipe may be required due to local ground conditions. Cut the PVC column to fit desired bury depth. Set PVC column in excavating pit.
2. Lay drain lines and water supply lines. Provide service shut off valve for maintenance. Flush the water supply line before attaching to the shut off valve.

Other Notes:

- The details on the attached pages show a suggested installation method. Depending on the climate and environmental conditions the suggested installation may be modified.
- Overall - for the freeze resistant to function properly the valve must be installed in a non-freezing area.

**SUGGESTED SITE PREPARATION DETAIL FOR THE
4410FR FTN. WHEN USING THE SANITARYFR1 VALVE**

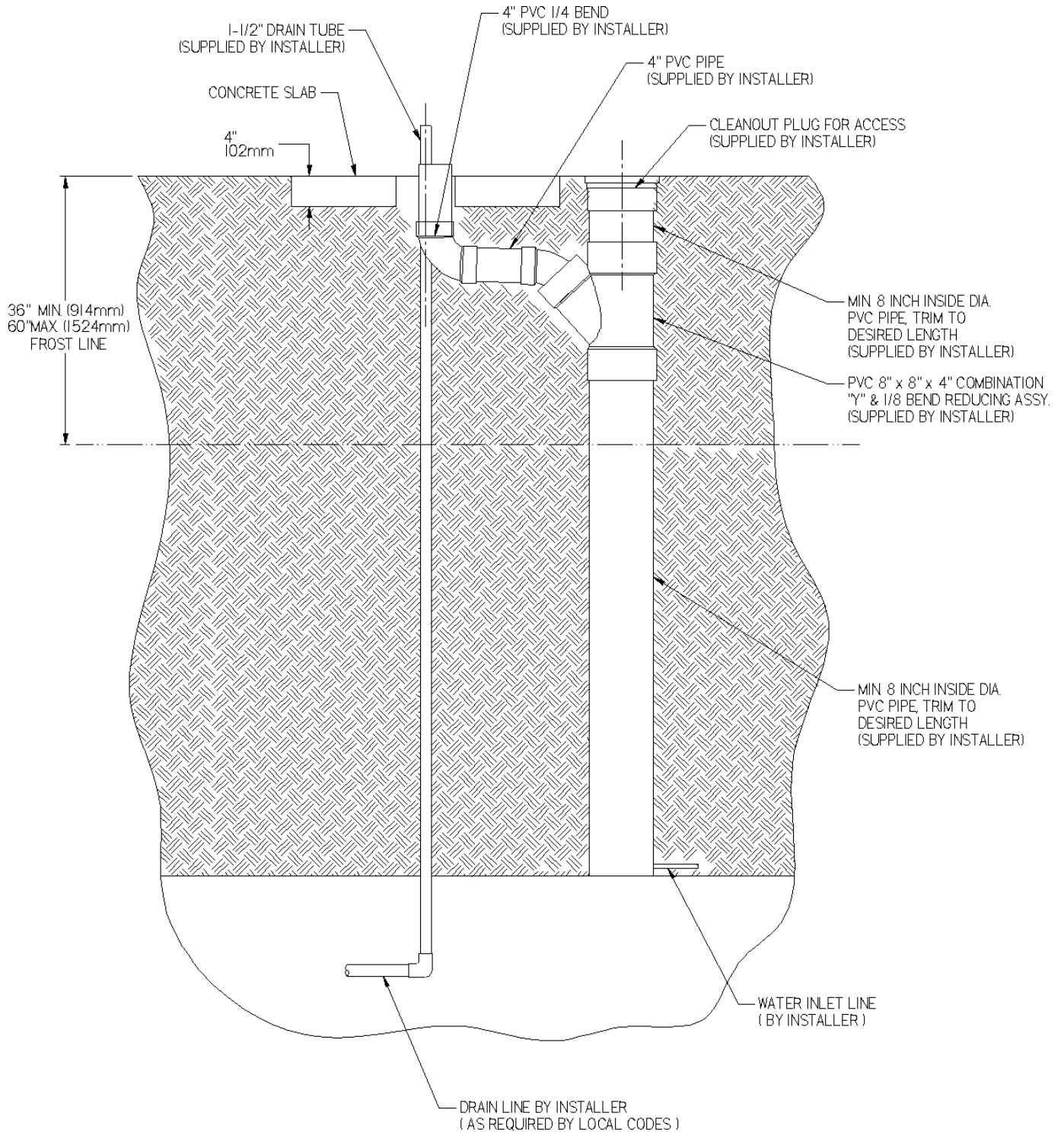
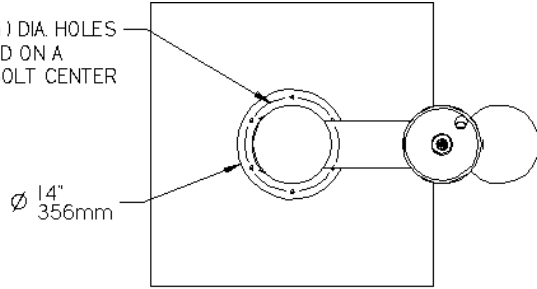

FIG. 1

SUGGESTED SITE PREPARATION DETAIL FOR THE 4410FR FTN. WHEN USING THE SANITARYFR1 VALVE

(6) 1/2" (13mm) DIA. HOLES
EQUALLY SPACED ON A
12" (305mm) BOLT CENTER



1-1/4" DRAIN TUBE
SUPPLIED WITH FTN.

AIR GAP ASSY.
SUPPLIED WITH VALVE

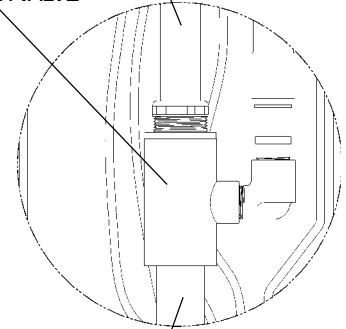

1-1/2" DRAIN TUBE
SUPPLIED BY INSTALLER

Detail A

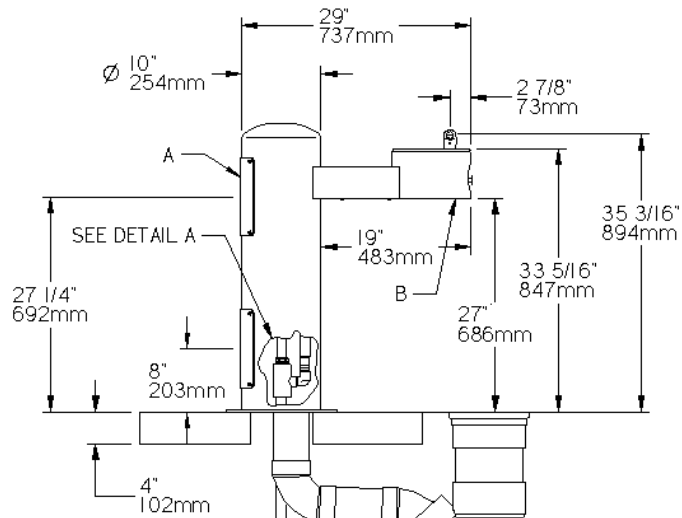

FIG. 2

LEGEND

A = ACCESS PANEL (8" X 10")
B = REMOVABLE BOTTOM COVER

DRAIN LINE BY INSTALLER
(AS REQUIRED BY LOCAL CODES)

WATER INLET LINE
(BY INSTALLER)

VALVE WATER LINE SUPPLIED
WITH A 1/4 x 1/2 NPT CONNECTOR

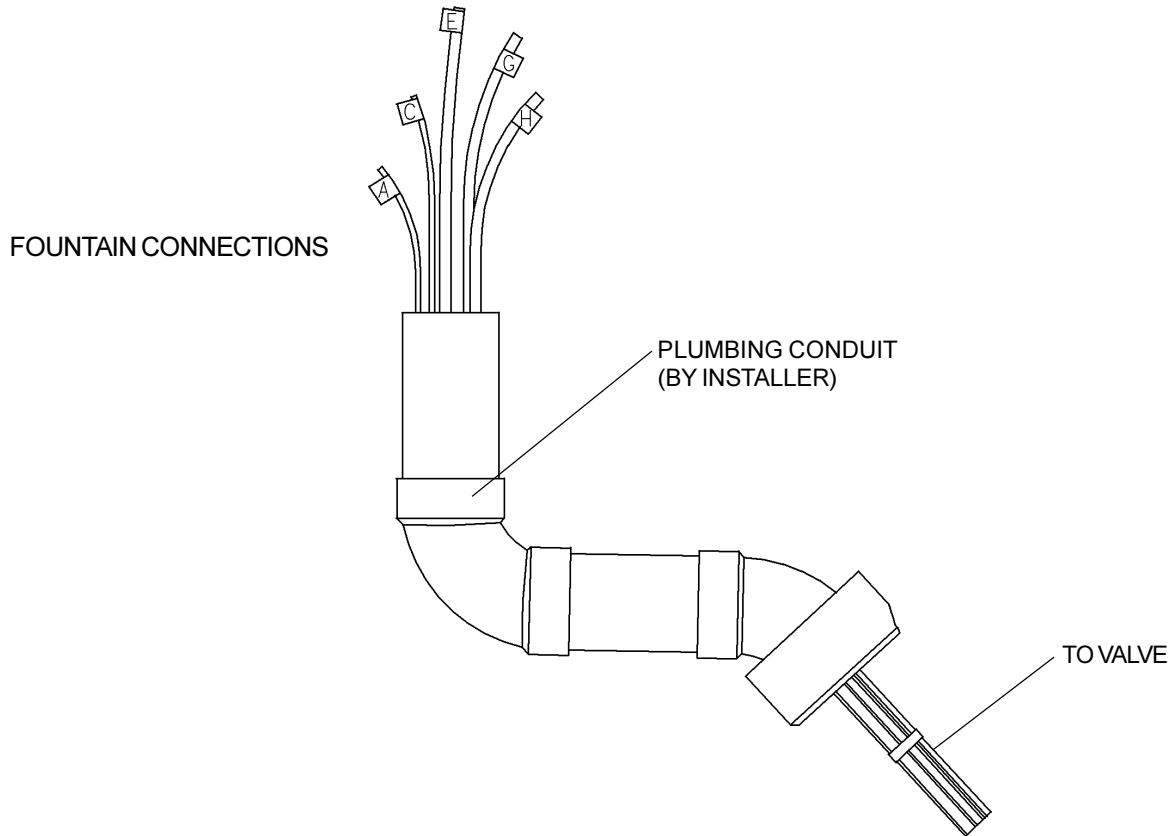
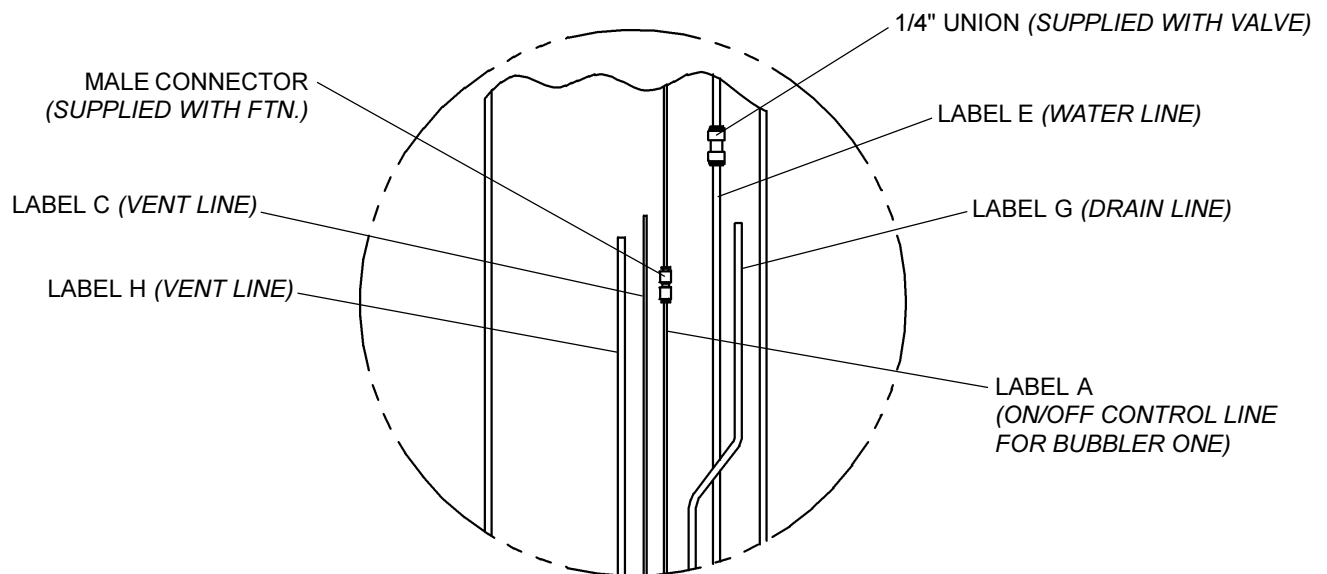

FIG. 3

INSTRUCTIONS FOR CONNECTING TUBES FROM VALVE TO FOUNTAIN

- Step 1 - Insert the 1/8" O.D. tube (Label A) into the connector (provided with fountain). Insert the 1/8" O.D. tube coming from the fountain push button actuator into the connector. Trim any excess length.
- Step 2 - Secure the 1/8" O.D. tube (Label C) to the waste line assembly. This line is a vent line and should be open to the air.
- Step 3 - Insert the 1/4" O.D. tube (Label E) into the 1/4" union (provided with valve assembly). Insert the 1/4" O.D. water line coming from the fountain into union. Trim any excess length.
- Step 4 - Insert the 1/4" O.D. tube (Label G) into the air gap assembly.
- Step 5 - Secure the 1/4" O.D. tube (Label H) to the waste line assembly. This line is a vent line and should be open to the air.



FOUNTAIN CONNECTIONS

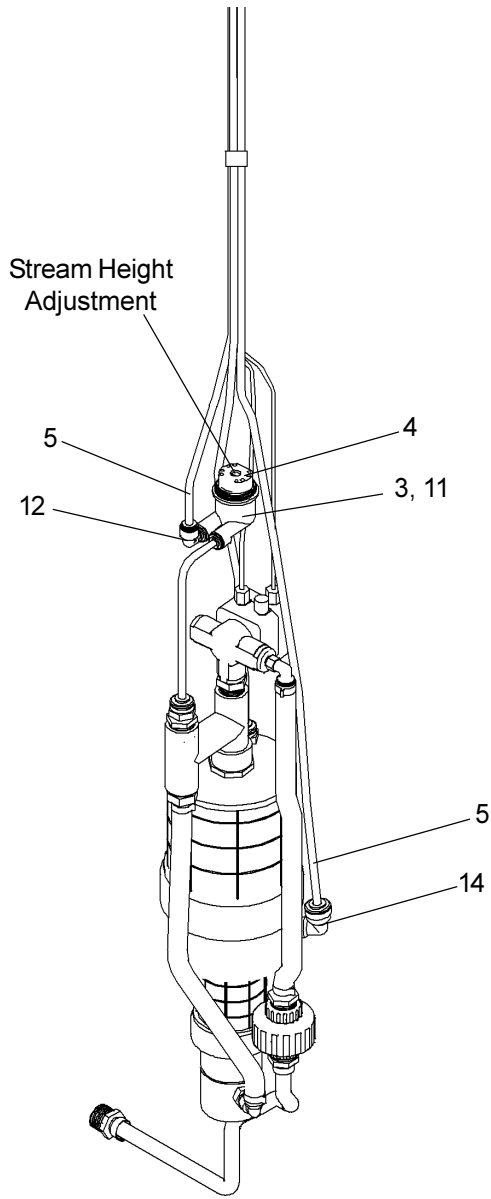

FIG. 4

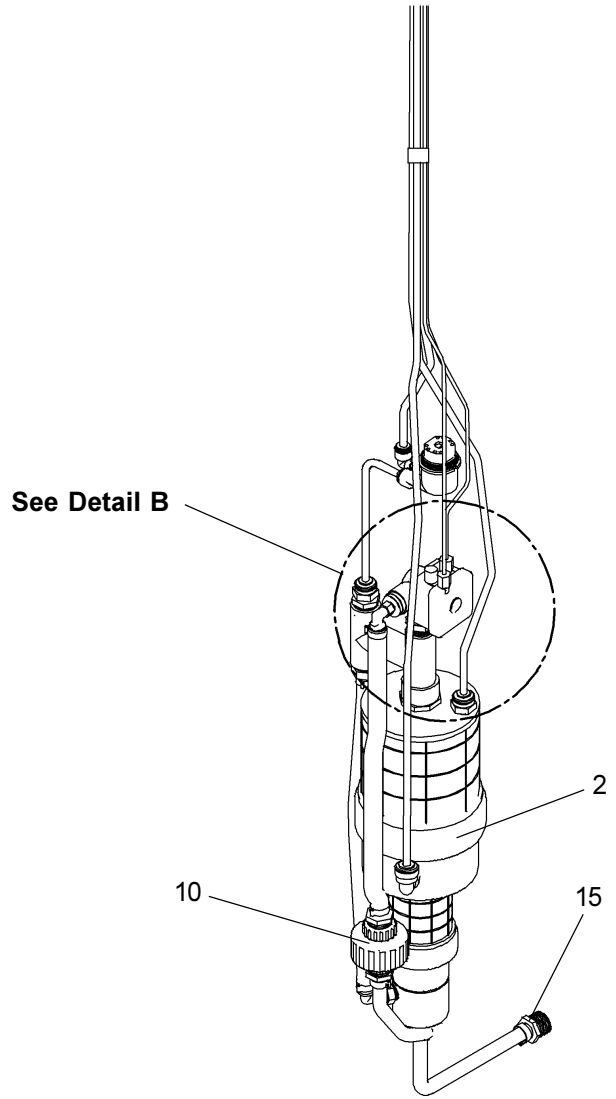
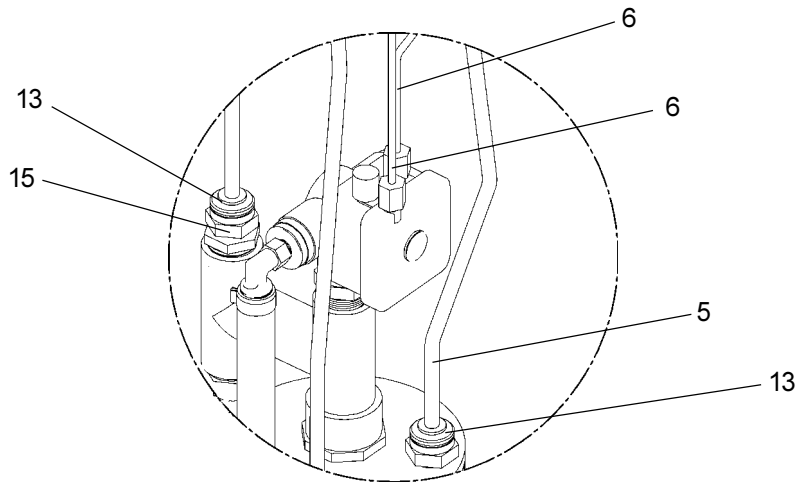

FIG. 5



Detail B

**The Following Items are included with
the SanitaryFR1 Valve**

PARTS LIST		
ITEM NO.	PART NO.	DESCRIPTION
1	110175443890	Hex Nut - 3/8-16
2	45806C	Single Valve
3	50986C	Regulator Holder
4	56082C	Regulator Nut
5	56092C	Poly Tubing - 1/4" (Cut To Length) - To Bubbler
6	56123C	Poly Tubing - 1/8" (Cut To Length) - To Actuator
7	56185C	Canister
8	56186C	Trap - Adaptor 1-1/2 x 1-1/4
9	56203C	Air Gap Assy.
10	56235C	Fitting - 1/2" Union w/Strainer
11	61313C	Regulator
12	70817C	Fitting - Elbow 1/4 Stem x 1/4 Tube
13	70828C	Fitting - Connector 1/4 x 1/4 NPTF
14	75639C	Fitting - Elbow 1/4 x 1/4 NPTF
15	75642C	Fitting - Adaptor 1/4 NPT x 1/2 NPT
16	75652C	U-Bolt
17	75653C	Nylon Strap - 6 ft.
NS	70683C	Fitting - Union 1/4

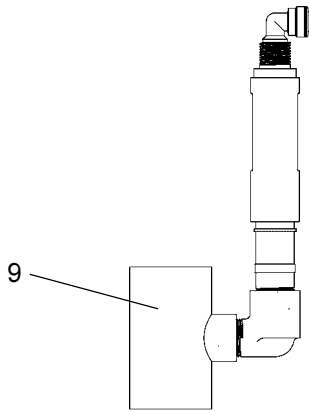

FIG. 6

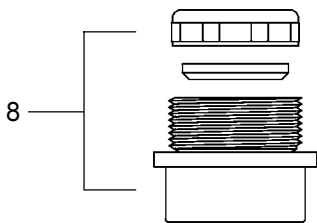

FIG. 7

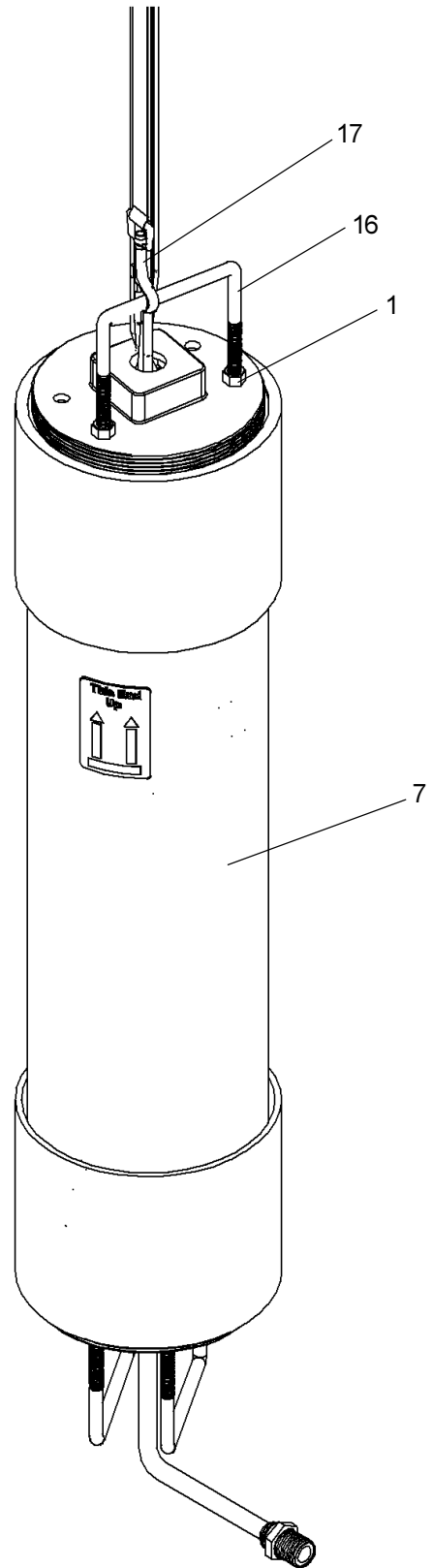

FIG. 8

The Following Items are included with the 4410FR Fountain

PARTS LIST		
ITEM NO.	PART NO.	DESCRIPTION
18	100147140560	Drain Gasket
19	100322740560	Washer
20	101570540560	Drain Gasket
21	15009C	Nipple Assy. - Bubbler
22	15014C	Retaining Nut
23	28467C	Basin
24	40045C	Hex Nut 1-5/16"
25	45392C	Bubbler
26	45403C	Push Button Actuator
27	45464C	Drain Plug 1-1/2"
28	45483C	Drain Tube
29	45824C	Fountain Body
30	45832C	Access Panel
31	45833C	Bottom Cover
32	45663C	Push Button Sleeve
33	56121C	Drain Elbow 1-1/4"
34	66346C	Drain Tube
35	66461C	Fitting - 1-1/4" x 1-1/4"
36	75535C	Pinned Torx Screw 1/4-20 x .75"
37	75588C	Slip Joint Nut 1-1/4"
38	75589C	Gasket
NS	75521C	Bit - Pinned Torx T-27
NS	75565C	Fitting - Double Male Connector
NS	75596C	Paint Touch-up (Pen)
NS	56092C	Poly Tubing - 1/4" (Cut To Length) - To Bubbler
NS	56123C	Poly Tubing - 1/8" (Cut To Length) - To Actuator
NS	28091C	Nameplate Insert

Touch-up Paint

For minor scratches a Touch-up Paint Stick is available. For repairing large defects, off-the-shelf aerosol paint from your local hardware store can be used. Listed are two suggested brandnames.

- Brandname: X-O
- Brandname: Ace Hardware
- XO-11 Hunter Green
- Rust Stop / Machine & Implement International Green

Trouble Shooting

Insufficient Bubbler Flow: Check that the shut-off valve is wide open. Verify minimum 20 PSI supply pressure. Clean inlet strainer screen located in the valve body. Clean rubber orifice in flow control located below frost line in bushing between barb fitting and valve.

No Flow: Check for leaks in the air tubing going from the push button to the valve. Make sure the air tubing compression nut is hand tight. Disconnect air tube from push button. Place finger over air outlet. Push button to test diaphragm. Tighten diaphragm cap screws. Replace diaphragm if necessary.

Continued Insufficient or Varied Height of Bubbler Flow:

- Replace flow control.
- Check for kinks in the tubing.
- Remove the cleanout plug from the PVC column. Remove the valve assembly from the PVC column by carefully pulling up on the strap and connecting tubing at the same time. Pressure test the valve assembly for leaks. Check stream height from the bubbler. Stream height is factory set at 35 PSI. If supply pressure varies greatly from this, adjust the screw on the regulator (Item 11, Fig. 4, Page 10). Clockwise adjustment will raise stream and counter-clockwise adjustment will lower stream. For best adjustment stream height should be approx. 1-1/2" (38mm) above the bubbler guard. Replace the valve into the PVC column. Make sure the supply hose coils into the bottom of the PVC column without any kinks and double check that the valve is positioned fully at the bottom of the PVC column.

Continuous Bubbler Flow: Insure that push button is not obstructed and springs back to normal position. Remove four screws which secure plastic diaphragm block to valve body. Pull plastic and rubber diaphragm assembly out of valve body. Locate tiny hole in rubber diaphragm just under lip of plastic part. Clean debris from this hole. Inspect valve seat for grooves. If valve seat was OK and diaphragm hole was free from debris, inspect rubber button located at center of floating steel disc in valve diaphragm block assembly. If button is worn, turn disc over or replace it. If diaphragm and seats are in good condition, stretch spring slightly. Spring is located behind floating stainless steel plate. Insure that air bleed port on valve plastic block assembly is not plugged.

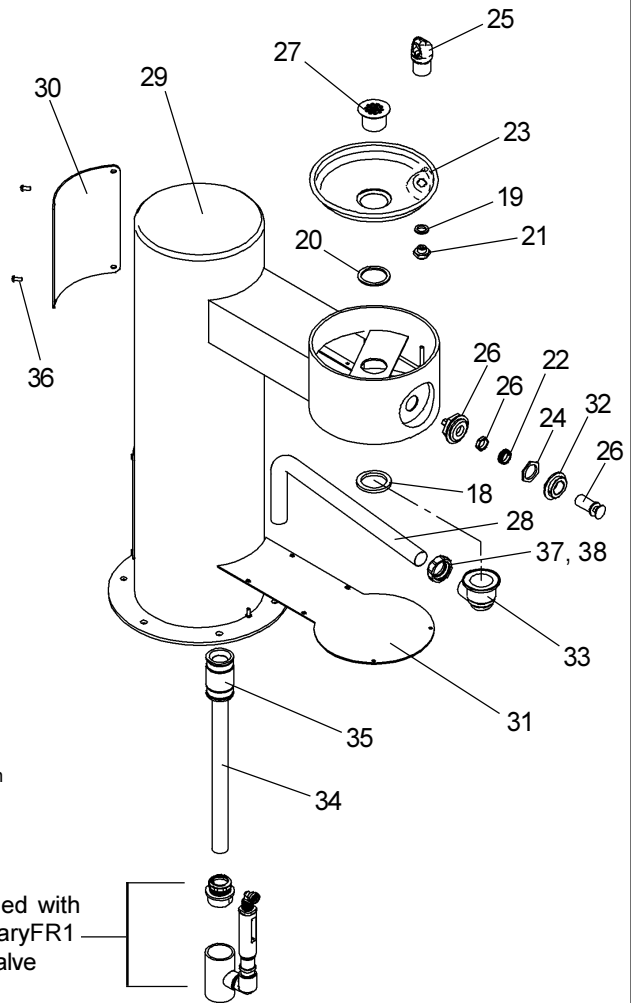

Included with SanitaryFR1 Valve

FIG. 9

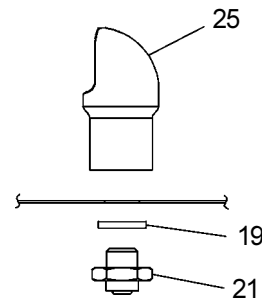

Bubbler Detail

Halsey Taylor
 2222 CAMDEN COURT
 OAK BROOK, IL 60523
 630.574.3500

FOR PARTS, CONTACT YOUR LOCAL DISTRIBUTOR OR CALL 1.800.323.0620

PRINTED IN U.S.A.