

Halsey Taylor Owners Manual

Freeze Resistant Wall Mounted Tubular Fountain

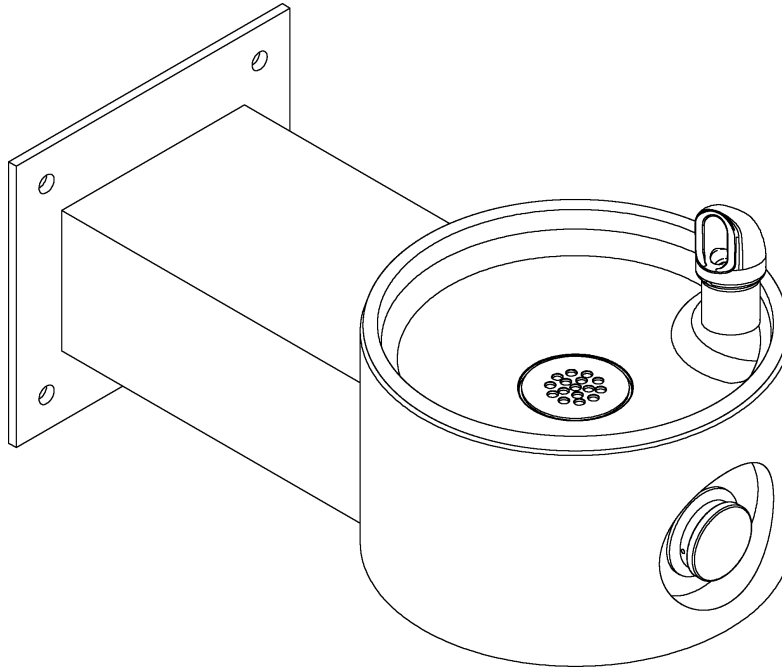

Installer

Halsey Taylor Fountains are among the easiest to install Fountains on the market today. To assure you install these models easily and correctly, PLEASE READ THESE SIMPLE INSTRUCTIONS BEFORE STARTING THE INSTALLATION. CHECK YOUR INSTALLATION FOR COMPLIANCE WITH PLUMBING, ELECTRICAL, AND OTHER APPLICABLE CODES. After installation, leave these instructions with the Fountain for future reference. This Freeze Resistant Fountain is shipped in two separate cartons. The second carton(s) contains the Freeze Resistant Package(s) **HTFRB1** that are installed on an interior heated wall. The interior space must maintain a minimum temperature of 50° F (10° C). Refer to the Freeze Resistant Package for the rough-in dimensions for installation.

IMPORTANT

ALL SERVICE TO BE PERFORMED BY AN AUTHORIZED SERVICE PERSON.

IMPORTANT! INSTALLER PLEASE NOTE.

THE GROUNDING OF ELECTRICAL EQUIPMENT SUCH AS TELEPHONE, COMPUTERS, ETC. TO WATER LINES IS A COMMON PROCEDURE. THIS GROUNDING MAY BE IN THE BUILDING OR MAY OCCUR AWAY FROM THE BUILDING. THIS GROUNDING CAN CAUSE ELECTRICAL FEEDBACK INTO A FOUNTAIN, CREATING AN ELECTROLYSIS WHICH CAUSES A METALLIC TASTE OR AN INCREASE IN THE METAL CONTENT OF THE WATER. THIS CONDITION IS AVOIDABLE BY USING THE PROPER MATERIALS AS INDICATED. ANY DRAIN FITTINGS PROVIDED BY THE INSTALLER SHOULD BE MADE OF PLASTIC TO ELECTRICALLY ISOLATE THE FOUNTAIN FROM THE BUILDING PLUMBING SYSTEM.

FIG. 1

**4405 FREEZE RESISTANT FOUNTAIN
MOUNTING BOLT AND ACCESS HOLE LAYOUT**

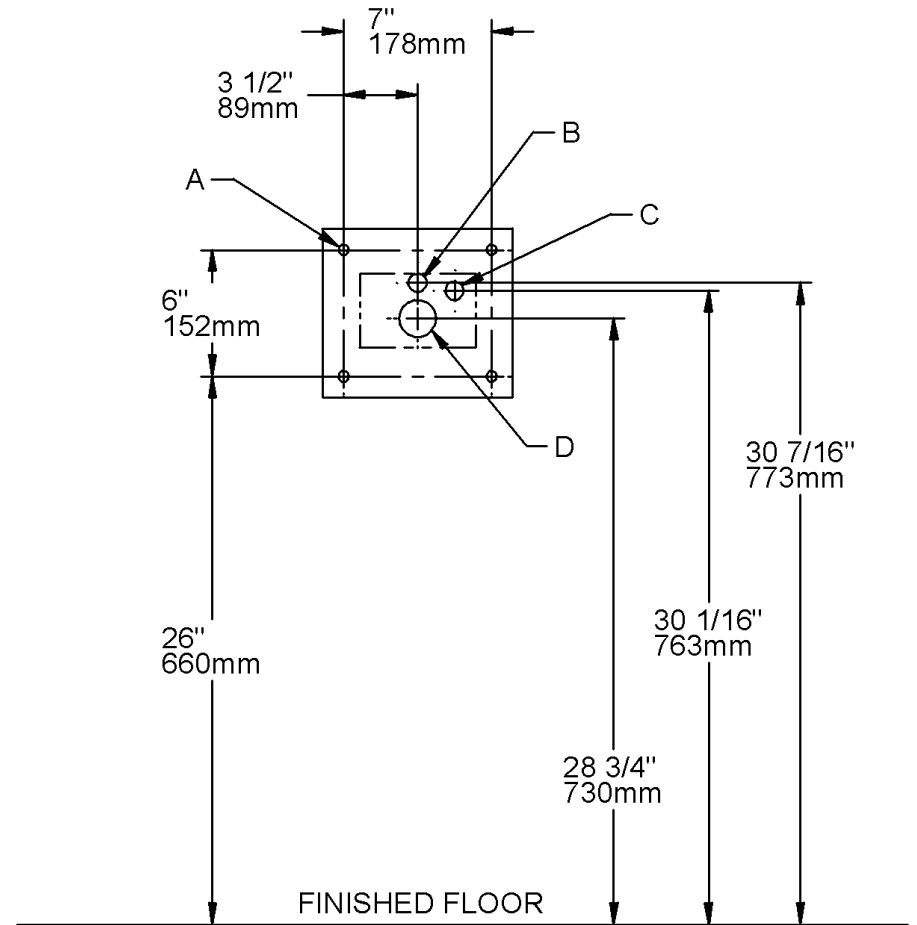
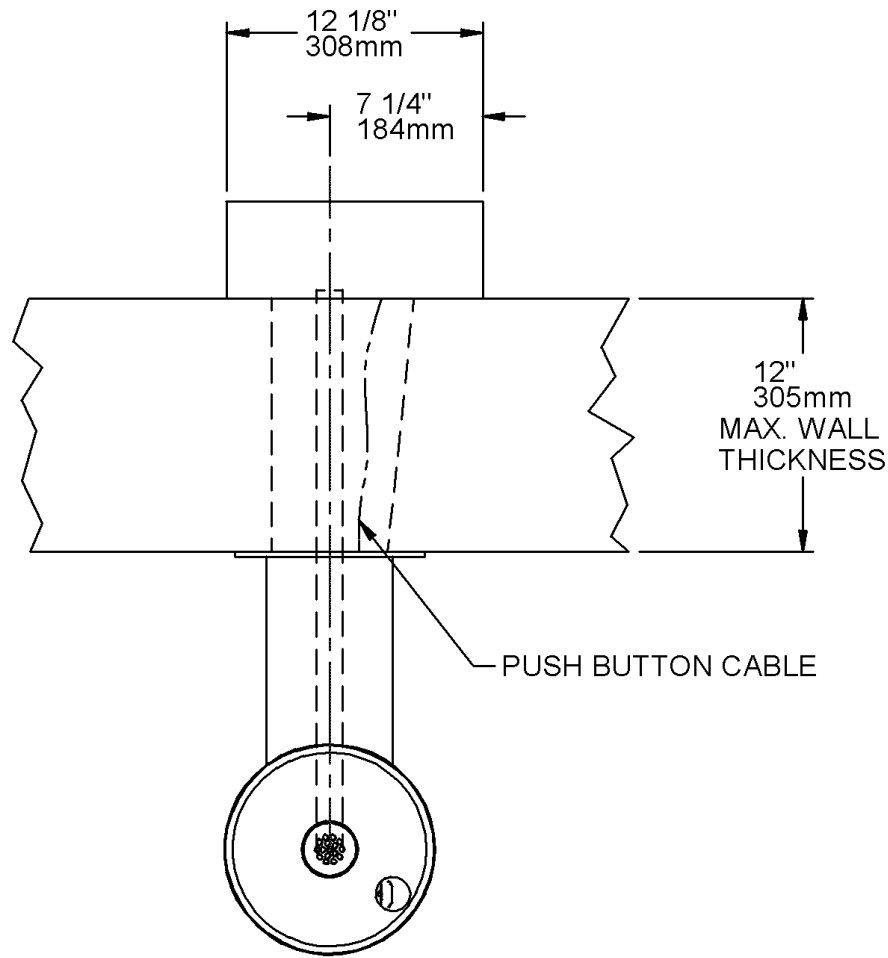

4405FRFTN

LEGEND

- A = MOUNTING BOLT LOCATIONS (4)(1/2" DIA. NOT PROVIDED).
- B = 7/8" DIA. (22mm) HOLE FOR WATER SUPPLY TUBE.
- C = 7/8" DIA. (22mm) HOLE FOR OPERATING CABLE.
- D = 2" DIA. (51mm) HOLE FOR WASTE LINE.

FIG. 2

4405 FREEZE RESISTANT FOUNTAIN
ROUGH-IN DRAWINGS

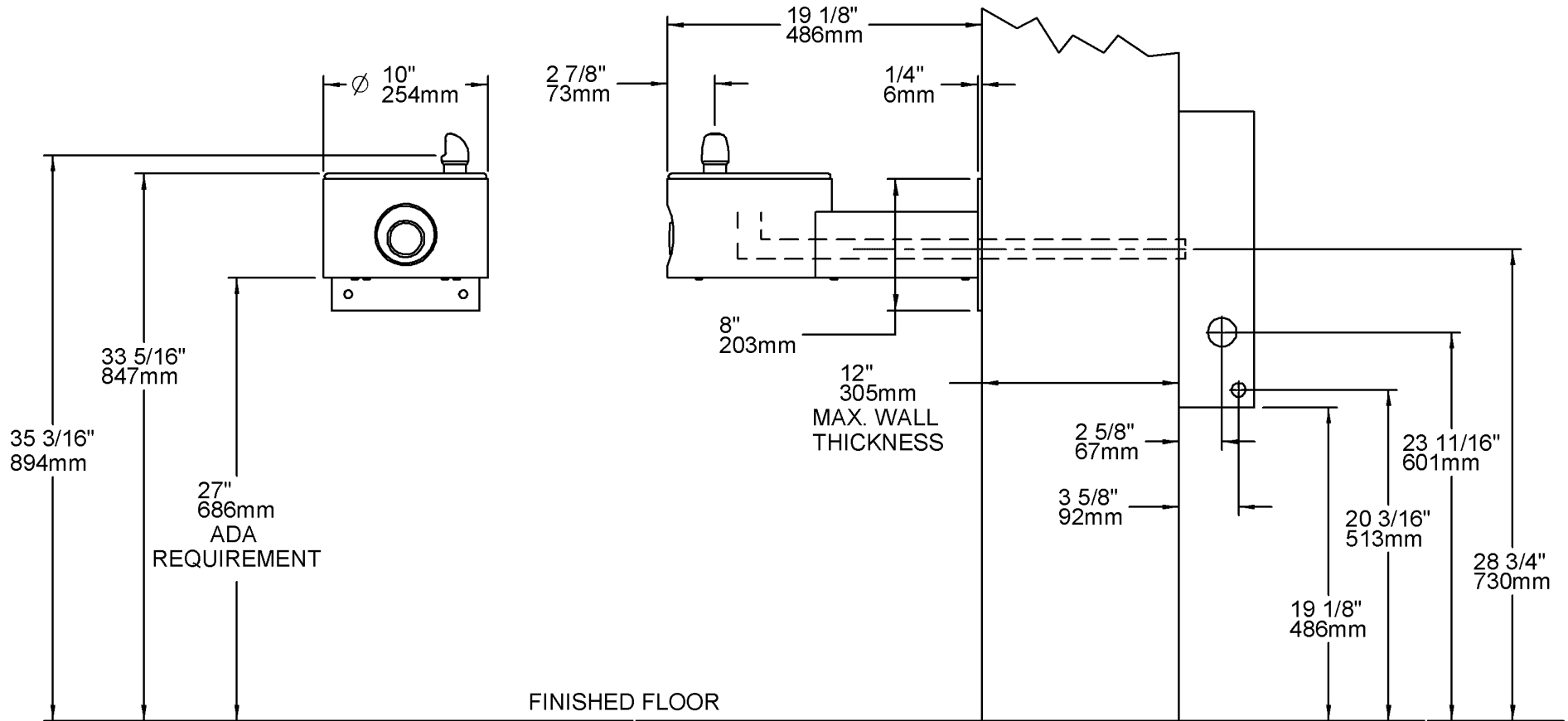

1. Wall should already be framed for the fountain using dimensions shown in Fig. 1. Shown dimensions pertain to installation location.

These dimensions are required for compliance with ANSI Standard A117.1, and ADA (Framing shown for reference only).

2. Remove bottom cover from fountain and save screws.

3. Install the fountain using bolts and washers (not provided). Tighten securely.

4. Attach drain tube to fountain and cut to required length using the freeze resistant box as a guide.

5. Install freeze-resistant box - see box instructions.

6. Replace bottom cover.

CABLE SHEATH ADJUSTMENT

To Increase Free Play



To Reduce Free Play

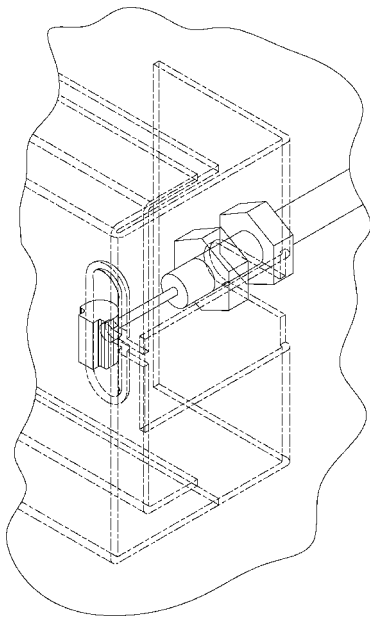

FIG.5

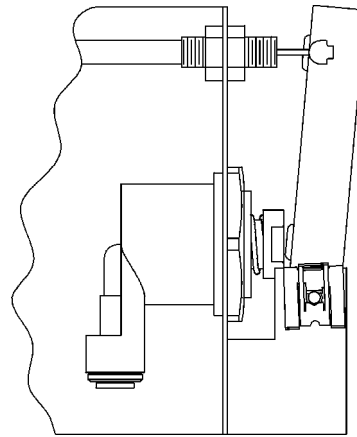

FIG.6

FIG.7

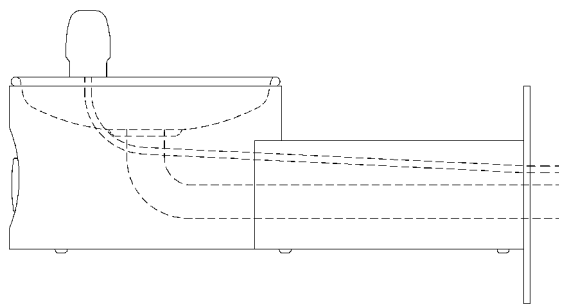
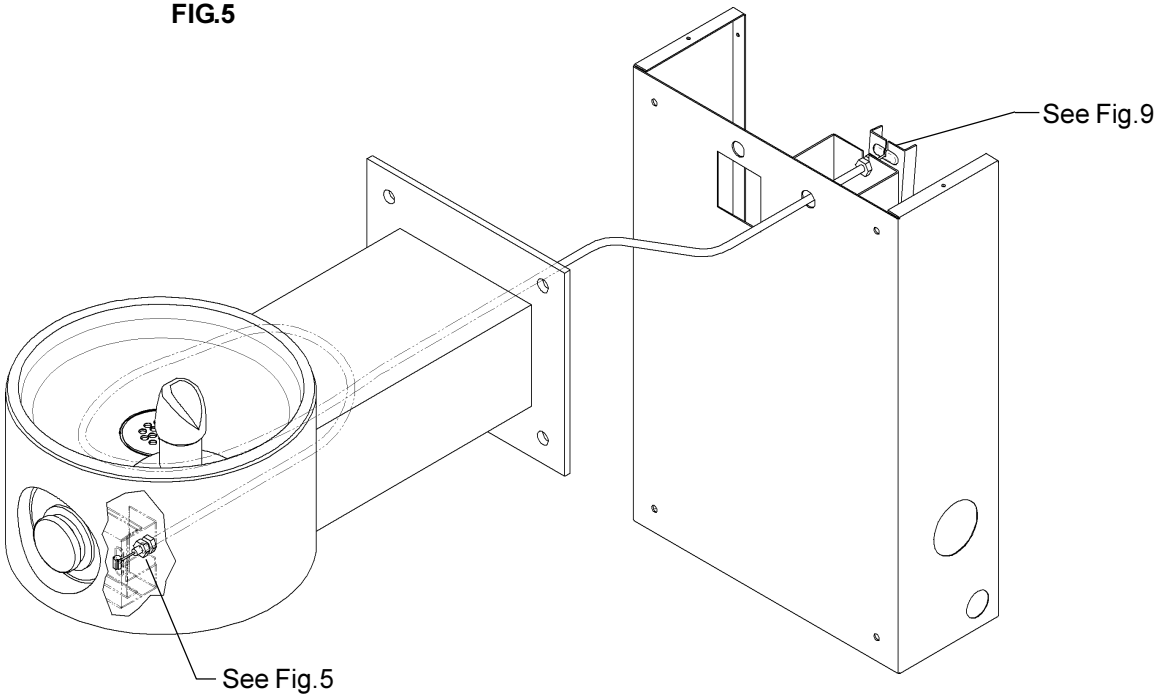

FIG.8

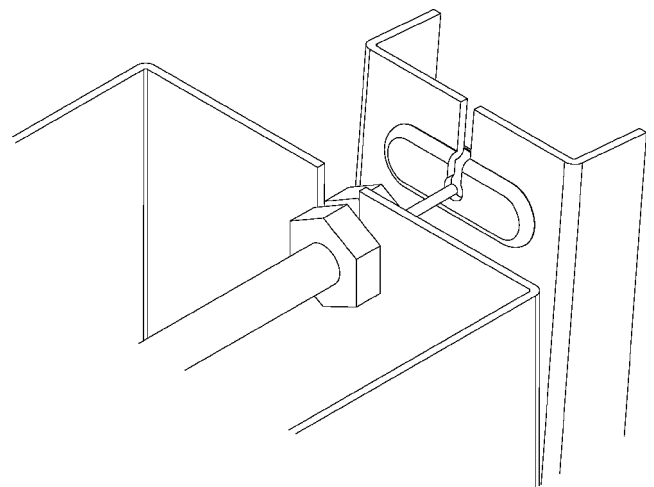

FIG.9

4405 FR FTN

The freeze resistant package must be mounted on an interior wall in a heated area. The room temperature of the interior heated area must be 50° F (10° C) or higher. The freeze resistant package may be surface or recessed mounted. If recess mounted the surface of the cover must be flush with the interior wall surface. The package is furnished with screws for mounting the cover to the box. If the box is recess mounted, do not fasten the top and bottom of the cover to the box. Use the holes on the front only.

1. Assemble the operating cable to the fountain bracket. (Fountain should be mounted to exterior wall) Create a loop in the cable and thread the free end of the cable through the wall into the freeze resistant box. The adjustment nuts should be in the middle of threaded area on the operating cable. See Figure 9
2. Connect free end of operating cable to the valve-operating bracket. The end of the cables must be recessed into the indents on the pivot brackets.
3. Remove cable free play by adjusting the jam nuts on the ends of the operating cable. See Figure 6
4. Connect water line from fountain bubbler into freeze resistant box. The connection to the box uses a quick connect water fitting. Position the water line, in the fountain, to drain back into interior mounted box. Any water left standing, in the exterior line, can freeze. See Fig. 8

To insert tubing, push tube straight into fitting until it reaches a positive stop. To remove tubing from the fittings, relieve water pressure, push in on dark gray collar while pulling out on the tubing. See Figure 11

5. Connect drain and water supply lines to the freeze resistant fountain. Refer to Figure 1 for component positions. Inline strainer must be used on the inlet water line. See Fig. 10

Start-up

1. Turn on building water supply and check all connections for leaks. Repair as required.
2. Stream height is factory set at 35 PSI. If stream height needs to be changed adjust the regulator in the freeze resistant package. Clockwise adjustment raises stream height, counter clockwise adjustment will lower stream.
3. Adjust operating cable as required. Cable system should have a minimal amount of free play to allow for proper valve operation. If the system is too tight the valve will stay in the on position creating constant water flow. Too much free play will result in non-operation of the valve with the push-buttons.
4. Note: Water from the drain back tube in the freeze resistant package, will continue to run while the valve is actuated.
5. After cable system is adjusted properly stuff flexible insulation into any openings between the outside wall and the interior box.
6. Recheck all connections. If all connections are leak free replace cover(s) on the freeze resistant box(es) and fountain(s).

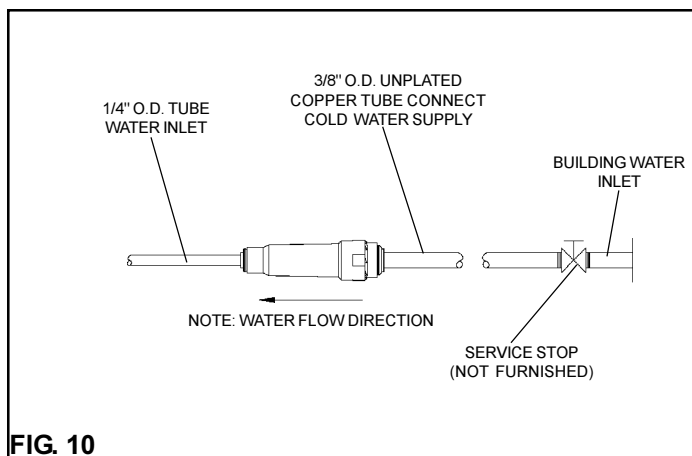

FIG. 10

OPERATION OF QUICK CONNECT FITTINGS

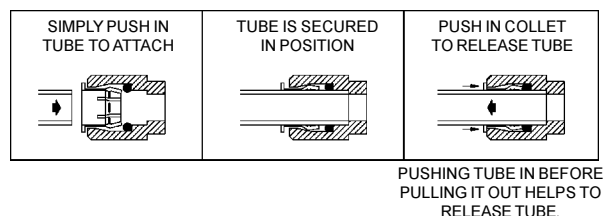

FIG. 11

THIS PAGE LEFT INTENTIONALLY BLANK.

THIS PAGE LEFT INTENTIONALLY BLANK.

ITEMIZED PARTS LIST

ITEM NO.	PART NO.	DESCRIPTION
1	100147140560	Drain Gasket
2	70425C	Pivot Rod
3	101570540560	Drain Gasket
4	70817C	1/4" X 1/4" Elbow Fitting
5	15009C	Nipple Assy. - Bubbler
6	28091C	Nameplate Insert
7	40045C	Hex Nut 1-5/16"
8	45392C	Bubbler
9	45464C	Drain Plug 1-1/2"
10	45823C	Fountain Body
11	45834C	Bottom Cover
12	45662C	Push Button
13	45663C	Push Button Sleeve
14	55919C	Push Button Extension
15	27945C	Basin Bracket
16	56121C	Drain Elbow 1-1/4"
17	56092C	Poly Tubing (Cut To Length)
18	27946C	Basin Pivot Bracket
19	51468C	Regulator Bumper
20	70022C	Set Screw #6-32 x .31"
21	28467C	Basin
22	75535C	Pinned Torx Screw 1/4-20 x .75"
23	100322740560	Washer
24	75588C	Slip Joint Nut 1-1/4"
25	75589C	Gasket
26	50198C	Snap Bushing
27	40206000	Retainer
28	70023C	Set Screw #6-32 x .12"
NS	75521C	Torx Bit T-27
NS	75539C	Allen Wrench
NS	75596C	Paint Touch-up (Pen)

Touch-up Paint

For minor scratches a Touch-up Paint Stick is available. For repairing large defects, off-the-shelf aerosol paint from your local hardware store can be used. Listed are two suggested brandnames.

- Brandname: X-O
XO-11 Hunter Green
- Brandname: Ace Hardware
Rust Stop / Machine & Implement
International Green

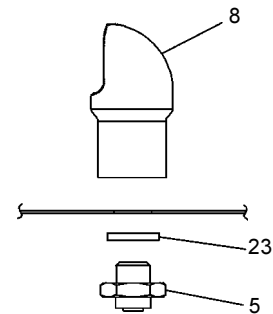
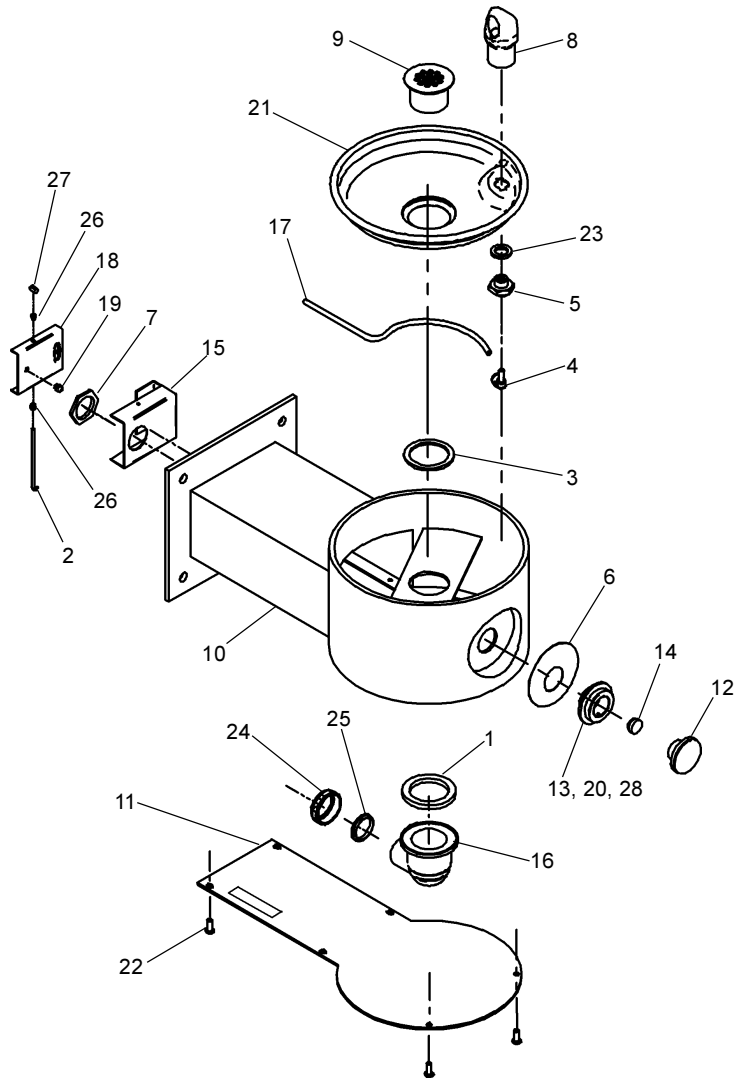

BUBBLER DETAIL