

Halsey Taylor Owners Manual

Non-Refrigerated 2634 Fountain



Installer

To assure you install this model easily and correctly, PLEASE READ THESE SIMPLE INSTRUCTIONS BEFORE STARTING THE INSTALLATION. CHECK YOUR INSTALLATION FOR COMPLIANCE WITH PLUMBING, ELECTRICAL AND OTHER APPLICABLE CODES. After installation, leave these instructions inside the fountain for future reference.

IMPORTANT

ALL SERVICE TO BE PERFORMED BY AN AUTHORIZED SERVICE PERSON

IMPORTANT! INSTALLER PLEASE NOTE.

THE GROUNDING OF ELECTRICAL EQUIPMENT SUCH AS TELEPHONE, COMPUTERS, ETC. TO WATER LINES IS A COMMON PROCEDURE. THIS GROUNDING MAY BE IN THE BUILDING OR MAY OCCUR AWAY FROM THE BUILDING. THIS GROUNDING CAN CAUSE ELECTRICAL FEEDBACK INTO A FOUNTAIN, CREATING AN ELECTROLYSIS WHICH CAUSES A METALLIC TASTE OR AN INCREASE IN THE METAL CONTENT OF THE WATER. THIS CONDITION IS AVOIDABLE BY USING THE PROPER MATERIALS AS INDICATED. ANY DRAIN FITTINGS PROVIDED BY THE INSTALLER SHOULD BE MADE OF PLASTIC TO ELECTRICALLY ISOLATE THE FOUNTAIN FROM THE BUILDING PLUMBING SYSTEM.

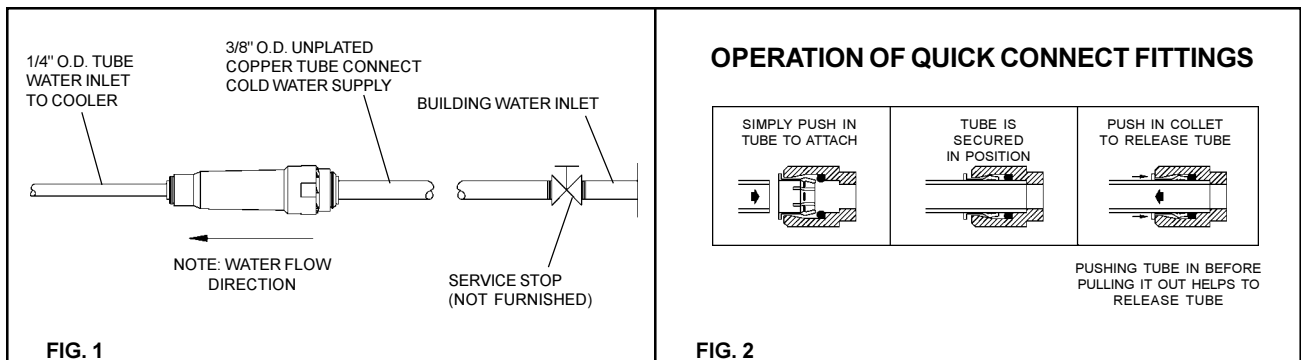

2634 FTN ROUGH-IN

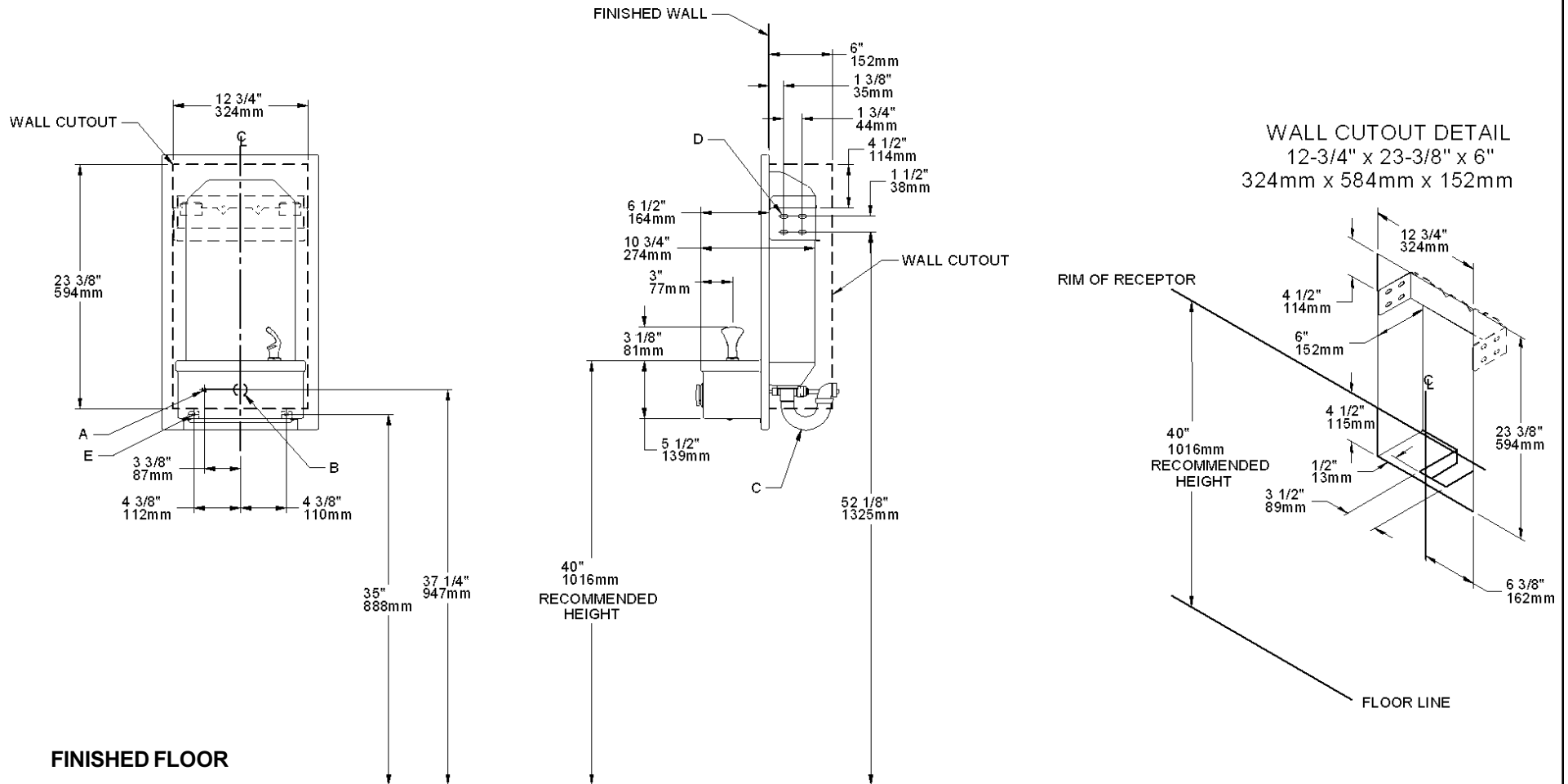

FIG. 3

LEGEND:

- A = RECOMMENDED WATER SUPPLY LOCATION 3/8 O.D. UNPLATED COPPER TUBE CONNECT
- B = RECOMMENDED LOCATION FOR WASTE OUTLET 1-1/4" O.D. DRAIN
- C = 1 1/4" O.D. TRAP FURNISHED
- D = 5/16" BOLT HOLES FOR SECURING HANGER BRACKET TO WALL CUTOUT
- E = 5/16" BOLT HOLES FOR SECURING BOTTOM OF FOUNTAIN WITH Z - BRACKET

INSTALLATION INSTRUCTIONS

1. Prepare the wall cutout opening(s). Refer to Wall Cutout Detail (See Fig 3).
2. Prepare waste connection and water supply hookup connection. Refer to roughin drawing for location details (See Fig. 3).
NOTE: Access to the rear of the fountain is desirable to ease installation. If rear access is not obtainable an access panel (furnished by others) should be installed below the fountain.
3. Install the fountain hanger bracket in the wall cutout. Refer to roughin drawing for details (See Fig 3). Remove bottom cover plate from the fountain. Save the cover plate and screws for reinstallation.
4. Install the Fountain. Place the fountain into the wall cutout. Slide the fountain down until it engages the hanger. Be sure the fountain is firmly engaged before releasing it. Secure the bottom of the fountain to the wall using the Z Bracket (included).
NOTE: SCREWS FOR ATTACHING THE FOUNTAIN HANGER BRACKET AND BASIN ARE NOT INCLUDED.
5. Make water supply connections from service stop to the fountain strainer (item 13). Attach an unplated and deburred copper water inlet line into the inlet side of strainer until it reaches a positive stop about 3/4", (See Figure 2, Page 1). Turn on water supply and check for leaks. Newly installed water supply line should be insulated after leak check is completed. **DO NOT SOLDER TUBES WHILE INSERTED INTO THE STRAINER AS DAMAGE TO THE O-RINGS MAY RESULT.**
6. These products are designed to operate on 20-105 PSIG supply line pressure. If inlet pressure is above 105 PSIG, a pressure regulator must be installed in the supply line. Any damage caused by reason of connecting these products to supply line pressure lower than 20 PSIG or higher than 105 PSIG is not covered by warranty.
7. Check stream height from bubbler. Stream height is factory set at 35-40 PSI. If supply pressure varies greatly from this, remove items 7 & 14 (See Fig 4, Page 4) by loosening set screw (item 19) and adjust the screw on regulator (item 16). Clockwise adjustment will raise stream height and counter-clockwise adjustment will lower stream height. For best adjustment stream height should be approximately 1-1/2" (38mm) above the bubbler guard (See Figure 5, Page 4).
8. Replace bottom access panel to fountain basin using screws provided. Tighten securely.

Care and Maintenance of Halsey Taylor Marblyte Fountains

Marblyte provides an extremely durable, nonporous surface which resists staining. Care is very simple. Routine cleaning with a soft sponge or cloth, or with water or non-abrasive aerosol foam cleaner, is all that is normally needed to give many years of trouble free service. Cleaners left standing on the fountain surface can dull the surface finish. Be certain to rinse all cleaning agents completely and polish with a soft cloth.

Harsh abrasive cleaners are not required and should not be used.

Mild abrasives such as liquid automotive cleaning compound or baking soda paste will remove simple scratches and stains. Cigarette burns can normally be removed without noticeable effect. Deeper scratches or gouges can be corrected with fine grit sandpaper (240 grit then 400 grit) or a green Scotchbrite pad.

To maintain or regain luster and make cleaning easier, periodic applications of automobile wax or like products will keep the finish looking like new.

PARTS LIST		
ITEM NO.	PART NO.	DESCRIPTION
1	100322740560	Gasket - Black
2	112627543890	Screw - 5/16-18 x 1" HHMS
3	15005C	Nut - Regulator Retaining
4	28378C	Cover - Plate
5	28406C	Brkt - Hanger Support
6	40045C	Nut - Hex
7	45662C	Button - Push
8	45736C	Nut - Regulator Mounting
9	45738C	Sleeve - Push Button
10	50986C	Holder - Regulator
11	51544C	Bubbler
12	56092C	Tube - Poly (Cut To Length)
13	55996C	Strainer
14	56087C	Extension - Push Button
15	56183C	Fountain - 2634 Body
16	61313C	Regulator
17	15029C	Nipple Assembly
18	70012C	Bubbler Lock Nut
19	70022C	Screw - #6-32 x .31" Set
20	75554C	Insert - Threaded
21	LK464	Drain
22	70023C	Screw - #6-32 x .12" Set
NS	28404C	Brkt - Z
NS	28405C	Brkt - Hanger
NS	75539C	Allen Wrench

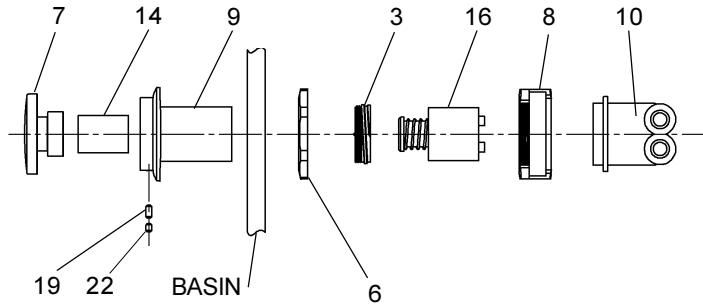

FIG. 4

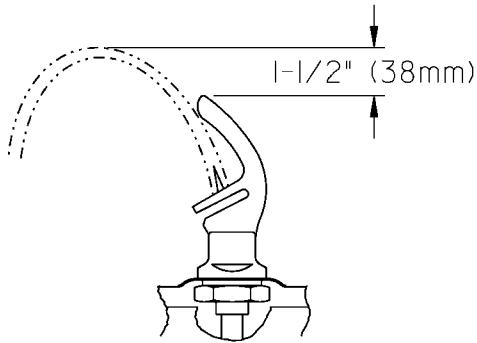
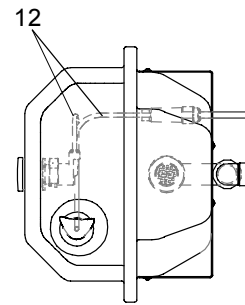
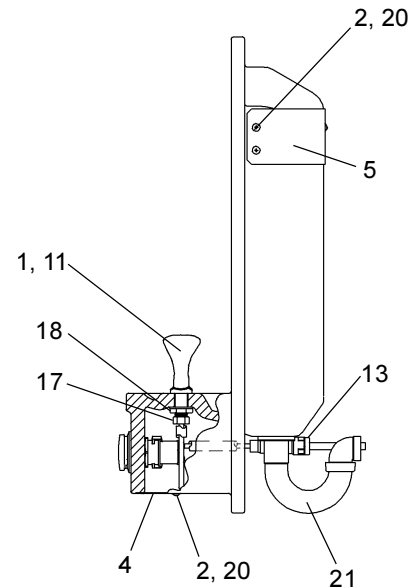
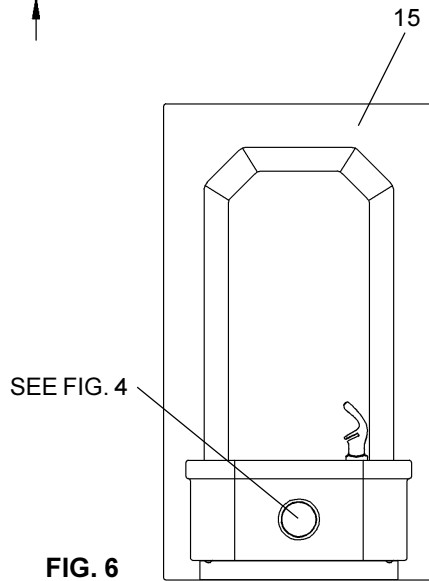

FIG. 5



TROUBLE SHOOTING & MAINTENANCE

Orifice Assy: Mineral deposits on orifice can cause water flow to spurt or not regulate. Mineral deposits may be removed from the orifice with a small round file not over 1/8" diameter or small diameter wire. **CAUTION: DO NOT** file or cut orifice material.

Stream Regulator: If orifice is free of material deposits, regulate flow as in instructions on page 3 (Step 7). If replacement is necessary, see parts list for correct regulator part number.

Actuation of Quick Connect Water Fittings: Cooler is provided with lead-free connectors which utilize an o-ring water seal. To remove tubing from the fitting, relieve water pressure, push in on the gray collar while pulling on the tubing.(See Figure 2, Page 1). To insert tubing, push tube straight into fitting until it reaches a positive stop, approximately 3/4".

Halsey Taylor

2222 CAMDEN COURT
OAK BROOK, IL 60523
630.574.3500