

# HALSEY TAYLOR OWNERS MANUAL

## *Classic™ Series Barrier-Free Water Coolers Refrigerated Fountains with Back Panel*



Figure 1 – HTER-Q



Figure 2 – HTSR-Q



Figure 3 – HTSER-Q



Figure 4 – HTESR-Q

Figure	Model	Description
1	HTER-Q	Classic™ Series - Extended Reach
2	HTSR-Q	Classic™ Series - Standard Reach
3	HTSER-Q	Classic™ Series - Dual Installation
4	HTESR-Q	Classic™ Series - Dual Installation

### INSTALLER



**CAUTION:** Review these instructions before beginning installation. Be sure that installation conforms to all plumbing, electrical and other applicable codes.



**WARNING:** When installation is complete, ensure these instructions are left in the plastic bag provided inside the installed unit for future reference.



**WARNING:** Service to be performed by authorized service personnel only.

**NOTE:** It is common practice to ground electrical hardware such as telephones, computers and other devices to available water lines. This can, however, cause electrical feedback in the plumbing circuit, which results in an “electrolysis” effect occurring in the fountain. This may result in water which has a metallic taste to it or has a noticeable increase in the metallic content of the water.

When inspecting plumbing circuit, remember the line may be grounded some distance from the installation, and may occur outside the building or area in which the unit is being installed.

This condition can be avoided (in most cases) by using recommended materials during installation. Any drain fittings provided by the installer should be made of **plastic** which will electronically isolate the fountain from the remainder of the building’s plumbing circuits.

HTERQ\*D HTSRQ\*D HTESRQ\*J HTSERQ\*J

**Installation Package**

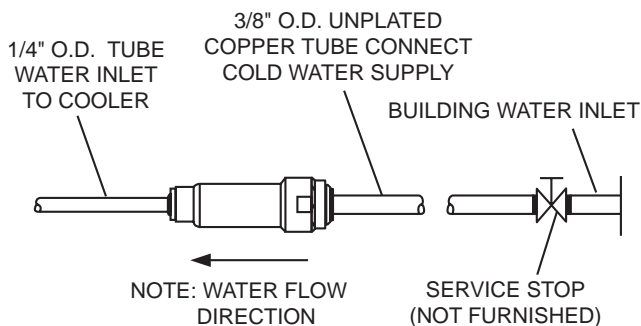

The components for installation are packed in three separate boxes, regardless of the type of unit being installed. The boxes contain the following:

- Box No. 1: Wall Frame(s)
- Box No. 2: Remote Chiller, SJ8-Q
- Box No. 3: Fountain(s), Arm(s) and Panels

Additional materials, as noted in the Parts List, are also shipped in these boxes.

Figure 5 – Water Supply Connections

**Parts List** **Number Required**

Item	Part No.	Description	HTER-Q	HTSR-Q	HTSER-Q	HTESR-Q	See Fig.
1	51546C	Bubbler – Satin	1	1	2	2	18
		Bubbler – Easy Flex™ (Option)	1	1	2	2	18
2	66318C	Tube Assembly – Bubbler	1	1	2	2	18
3	10080C	Nipple – Bubbler (Included w/item 2)	1	1	2	2	-
4	100322740560	Gasket – Bubbler	2	2	4	4	18
5	160270508640	Strainer Plate	1	1	2	4	18
6	161637308640	Drain Plug	1	1	2	2	18
7	100147140560	Gasket – Drain	1	1	2	2	18
8	66346C	Tube – Waste (HTER-Q)	1	-	1	1	18
	66343C	Tube – Waste (HTSR-Q)	-	1	1	1	18
9	26868C	Basin – Stainless Steel (HTER-Q)	1	-	1	1	18
	26870C	Basin – Stainless Steel (HTSR-Q)	-	1	1	1	18
10	23001C	Cover Bottom (HTER-Q)	1	-	1	1	18
	23002C	Cover Bottom (HTSR-Q)	-	1	1	1	18
11	26837C	Upper Panel – Stainless Steel (HTER-Q)	1	-	-	-	14, 18
	26835C	Upper Panel – Stainless Steel (HTSR-Q)	-	1	-	-	14, 18
	26839C	Upper Panel – Stainless Steel (HTSER-Q)	-	-	1	-	14, 18
	27028C	Upper Panel – Stainless Steel (HTESR-Q)	-	-	-	1	14, 18
12	26833C	Lower Panel – Stainless Steel (HTER-Q/HTSR-Q)	1	1	-	-	16, 18
	27026C	Lower Panel – Stainless Steel (HTSER-Q/HTESR-Q)	-	-	1	1	16, 18
13	56121C	Elbow – Drain	1	1	1	1	18
14	75588C	Nut – 1-1/4" Slip Joint	1	1	2	2	18
15	55996C	Strainer	1	1	2	2	19, 20
16	70745C	Union 3/8" x 1/4" Tube	1	1	1	1	19, 20
17	70852C	Tee – 3/8"	-	-	1	1	20
18	70870C	Union – 3/8"	1	1	-	-	19
N-S	70055C	Nut – Speed	1	1	1	1	-

**NOTE:** N-S means Not Shown.



Figure 6 – HTSER-Q Rough-In

1. **Cut a rectangular wall opening** 37-1/2" (953 mm) W x 37-3/4" H (959 mm) and 4-1/2" (114 mm) above the floor line (see Figure 7). The dimensions are required to obtain proper rim and bubbler heights for compliance with ANSI standard A117.1.
2. **Reinforce the wall opening** on all sides to adequately support the water fountain. This reinforcement must support up to 150 lbs. static load and provide a means for securing the frame assembly in place.  
**NOTE:** Building construction must allow for adequate air flow on both sides and top of remote chiller unit a minimum of 4" (102 mm) is required.
3. **Install plumbing and electrical rough-ins.** A junction box for a (3) wire, 10 amp branch circuit is provided on the inside of the chiller. (Standard 120 Volts, 60 Hz, and single phase.)
4. **Remove frames and related hardware** from packaging. Release the two shelf rods by cutting cable ties. Attach the two frames together through the upright supports with (4) 5/16" x 3/4" (19 mm) long bolts and nuts (not provided). Tighten securely.

**MAKE SURE FRAME CONFIGURATION MATCHES THE COOLER TO BE INSTALLED**

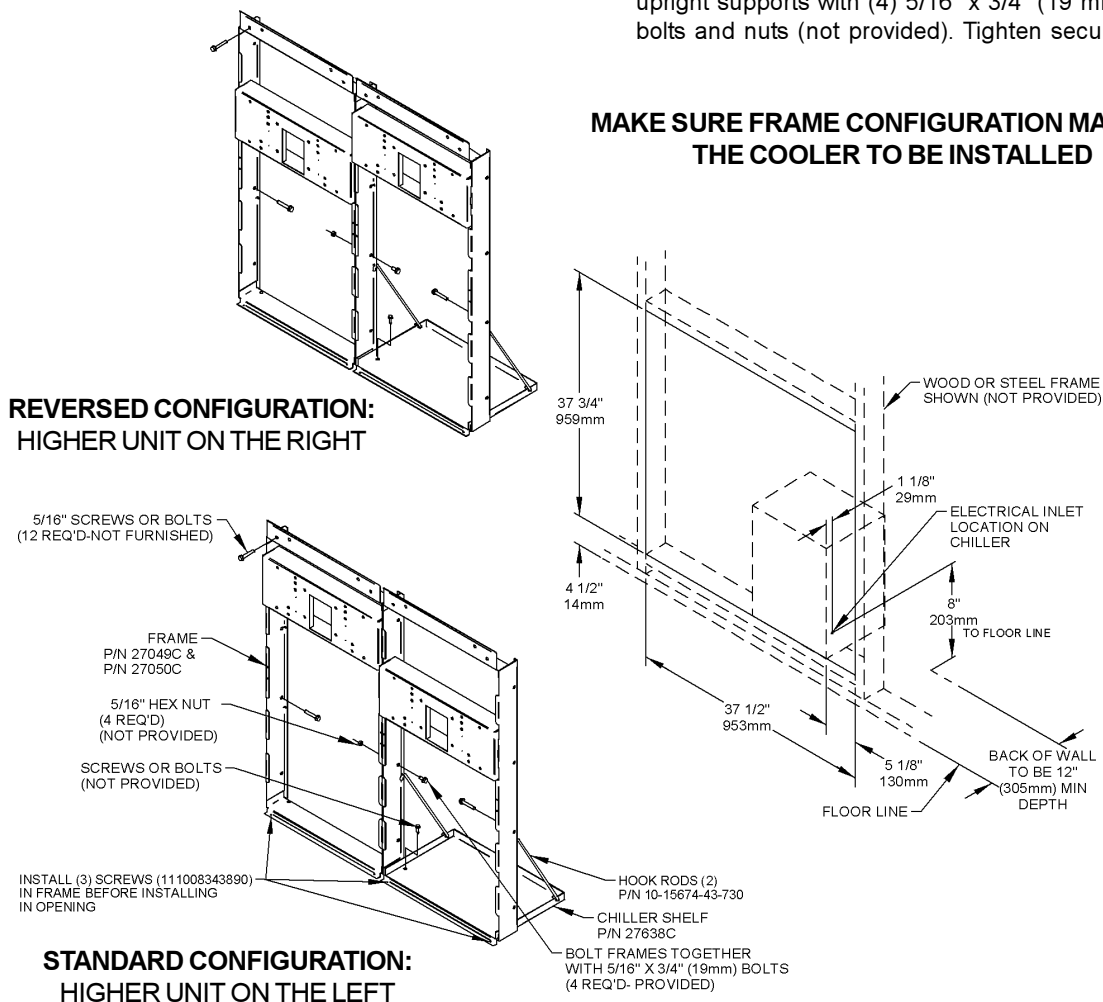

Figure 7 – Rough-In Assembly Dual-Station Mounting Frames

5. **Install the frame assembly squarely in wall opening** with frame upright support edges flush with the finished wall face. Secure the frame to the wall through holes with (12) 5/16" bolts or screws (not provided). Tighten securely.

**NOTE:** Be sure that frame is squared in location. Do not use less than required screw quantity and size.

6. **Attach the chiller shelf support rods** to the right side of the frame uprights at the second set of holes counting from the bottom and to the shelf at the (2) side holes. Line up the other shelf holes with the frame bottom holes and fasten the assembly to the wall opening using appropriately sized screws or bolts and nuts (not provided).

**MODEL HT-SER SHOWN**

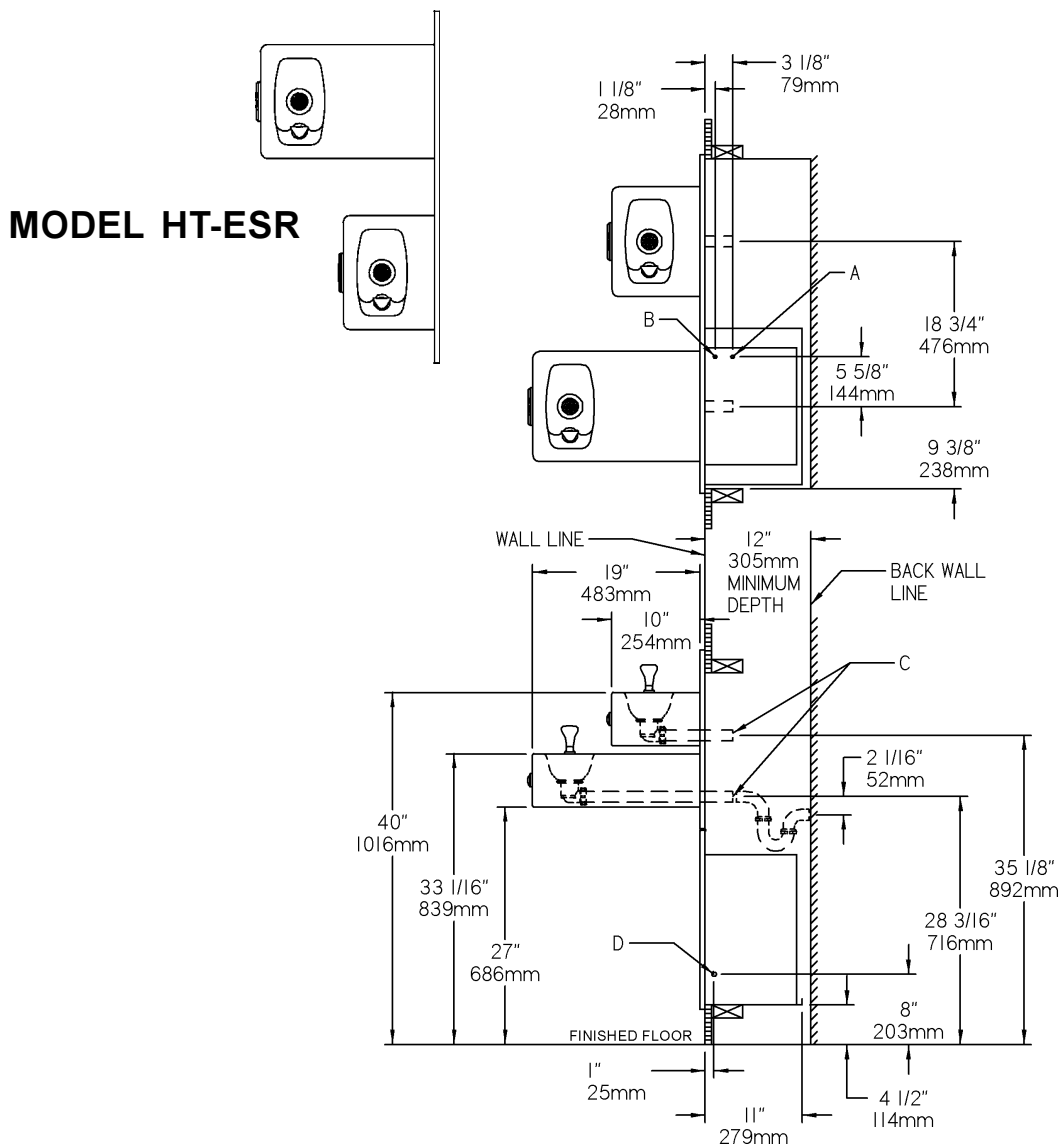

**Legend**

Item	Description
A	3/8" O.D. Tube - Water Outlet Connection
B	3/8" O.D. Tube - Water Inlet Connection
C	1-1/4" O.D. Tube - Waste Tube - <i>Not provided</i>
D	Electrical Inlet on Chiller

Figure 8 - HTSER-Q/HTESR-Q Rough-In Dimensions

HTERQ\*D HTSRQ\*D HTSRQ\*J HTSERQ\*J  
 Models  
 HTER-Q – HTSR-Q

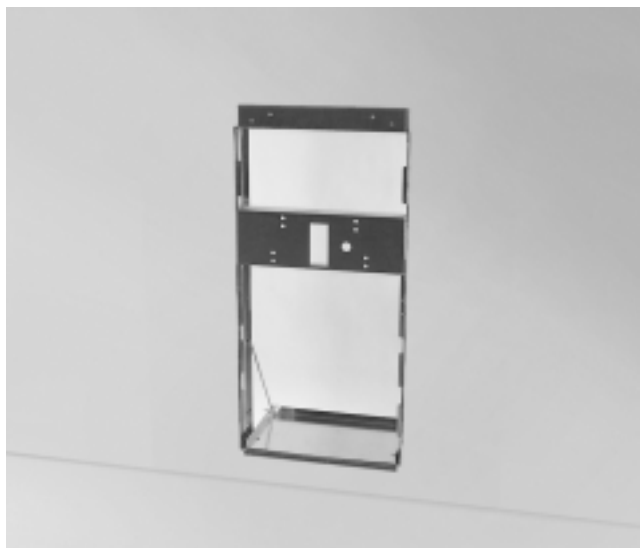

Figure 9 – HTER-Q/HTSR-Q Rough-In

1. **Cut a rectangular wall opening** 18-3/4" (475 mm) W x 37-3/4" H (959 mm) and 4-1/2" (114 mm) above the floor line (see Figure 10). The dimensions are required to obtain proper rim and bubbler heights for compliance with ANSI standard A117.1.
2. **Reinforce the wall opening** on all sides to adequately support the water fountain. This reinforcement must support up to 150 lbs. static load and provide a means for securing the frame assembly in place.  
**NOTE:** Building construction must allow for adequate air flow on both sides and top of remote chiller unit. Minimum of 4" (102 mm) is required.
3. **Install plumbing and electrical rough-ins.** A junction box for a (3) wire, 10 amp branch circuit is provided on the inside of the chiller. (Standard 120 Volts, 60 Hz, and single phase.)
4. **Remove frame and related hardware** from packaging. Release the two shelf rods by cutting cable ties.

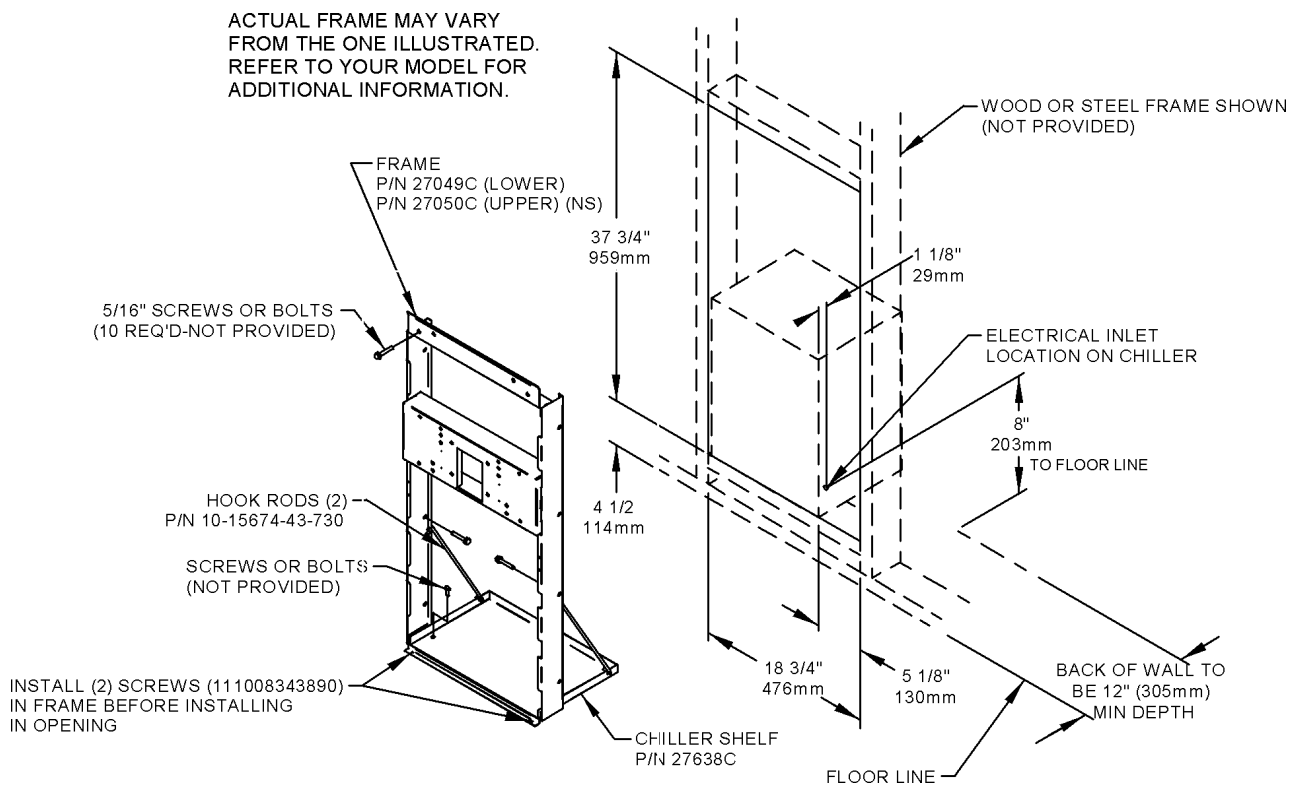
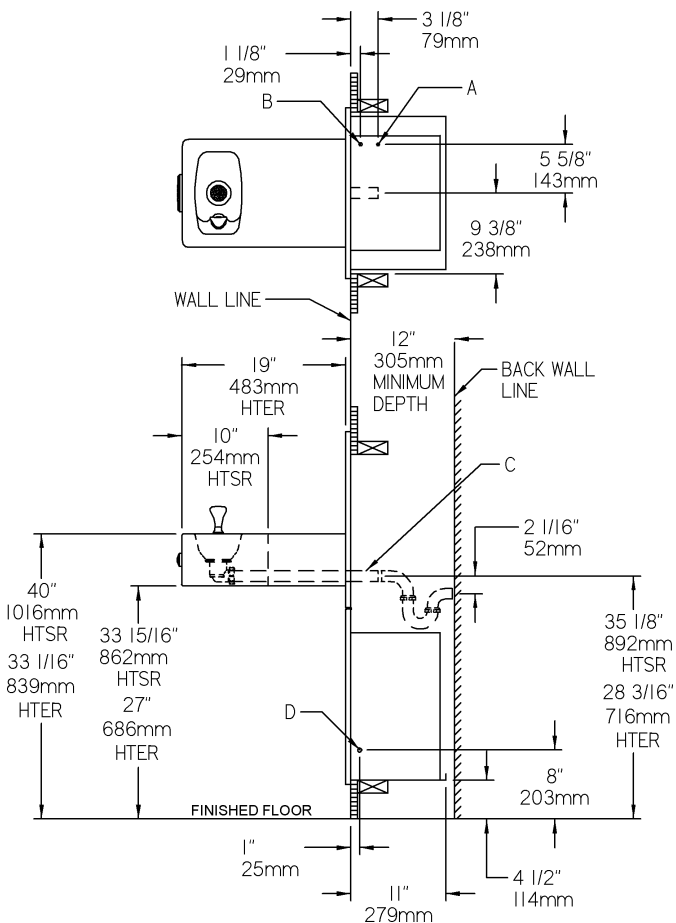

Figure 10 – Rough-In Assembly  
 Single-Station Mounting Frames

5. **Install the frame squarely in wall** opening with frame upright edges flush with the finished wall surface. Place shelf inside frame and line up the (2) holes on each. Insert loose ends of rods into holes on sides of shelf panel. Using appropriately sized screws or bolts (not provided), fasten the shelf and frame to the bottom of wall opening. Secure the frame sides and top to the wall using (10) 5/16" bolts or screws (not provided).

**NOTE:** Be sure that frame is squared in location. Do not use less than the required screw quantity and size.

### MODELS HT-ER/HTSR



#### Legend

Item	Description
A	3/8" O.D. Tube - Water Outlet Connection
B	3/8" O.D. Tube - Water Inlet Connection
C	1-1/4" O.D. Tube - Waste Tube - <i>Not provided</i>
D	Electrical Inlet on Chiller

Figure 11 – HTER-Q/HTSR-Q Rough-In Dimensions

### REQUIRED TOOLS AND MATERIALS

These tables show special tools and/or additional materials (not provided) which are necessary to complete installation of these units:

#### Special Tools

Item	Description	Quantity
	NONE	

#### Additional Materials

Item	Description	Quantity
1	Unplated copper inlet pipe	
2	Service Stop	

### HTER-Q/HTSR-Q/HTSER-Q/HTESR-Q INSTALLATION

1. Assemble and place frame in wall as shown on preceding pages.
2. **Install chiller:** Remove front panel of chiller. Remove and discard cardboard inner pack from between compressor and side panel. Slide chiller onto the shelf and position it to the left within the guides on the shelf.

**NOTE:** Building construction must allow for adequate air flow on both sides, top and back of chiller. A minimum of 4" (102mm) on both sides and top is required. See chiller installation for additional instructions.

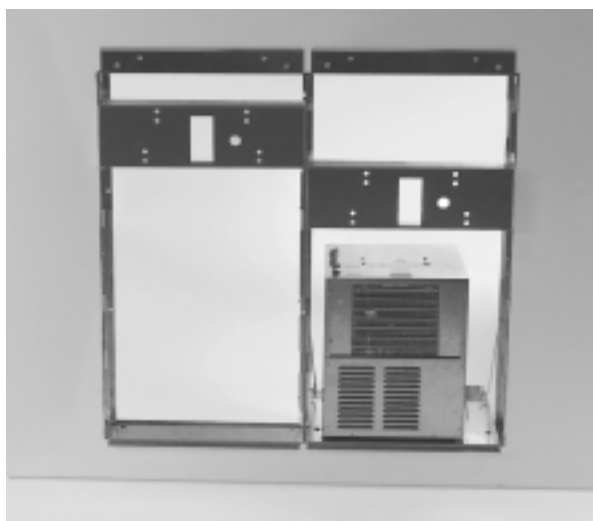

Figure 12 – Chiller Installation

3. Make water supply connections: Attach an unplated copper water inlet line and a service stop (not provided) to the chiller. Inlet port is marked on the chiller (3/8" O.D. copper tube). Bend the copper tube (provided) at an appropriate length from the chiller to opening in frame. Install a 3/8" O.D. tube tee fitting (provided) on the marked chiller outlet port. Turn on the water supply and flush the line thoroughly.
4. **Hang the upper panel on the mounting frame hanger:** Align holes in the panel with the holes in the mounting frame. Be sure that panel is engaged with hanger at top of frame before releasing it.

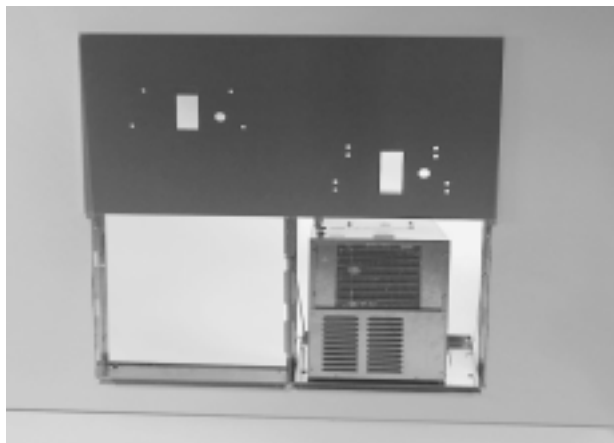

Figure 13 – Upper Panel Installation

5. Install fountain: Remove access cover plate on underside of fountains and SAVE the screws. Mount the fountains to the upper panel and frame with (4) 5/16" x 3/4" (19mm) long bolts and nuts provided. Tighten securely.

**Note:** With HTSER-Q/HTESR-Q models, the standard reach fountain must be mounted at the upper position on panel.



Figure 14 – Fountain Installation

6. Remove elbow from end of p-trap and attach it to drain tube. Re-attach elbow to p-trap and cut waste tube to required length using plumbing hardware and trap as a guide.
7. Make connection between remote chiller outlet tube and fountain strainer. Insert the water inlet line into inlet side of strainer by pushing it in until it reaches a positive stop, approximately 3/4" (19mm). Turn on water supply and check for leaks.

**CAUTION:** DO NOT SOLDER tubes into the strainer as damage to o-rings may result.

8. These products are designed to operate on 20-105 PSIG supply line pressure. If inlet pressure is above 105 PSIG, a pressure regulator must be installed in the supply line.

**CAUTION:** Any damage caused by connecting these products to a supply line with pressure lower than 20 PSIG or higher than 105 PSIG IS NOT covered under warranty.

9. Make electrical connections to the chiller. See chiller instructions.
10. Check stream height from bubbler. Stream height is factory set at 45-50 PSI. If supply pressure varies greatly from this, remove the cover bottom (Item 10 – Figure 18) and adjust the screw on the regulator (Item 13 – Figure 15). Clockwise adjustment will raise stream height and counterclockwise movement will lower stream height. For best adjustment, stream height should be approximately 1-1/2" (38mm) above the bubbler guard. (See Figure 17).
11. Mount lower panel. Loosen the two (2) #10-24 x 5/8" (16mm) screws at frame bottom lip. Slide upper tongue of lower panel under lower edge of already installed upper panel. Tighten previously loosened screws securely.

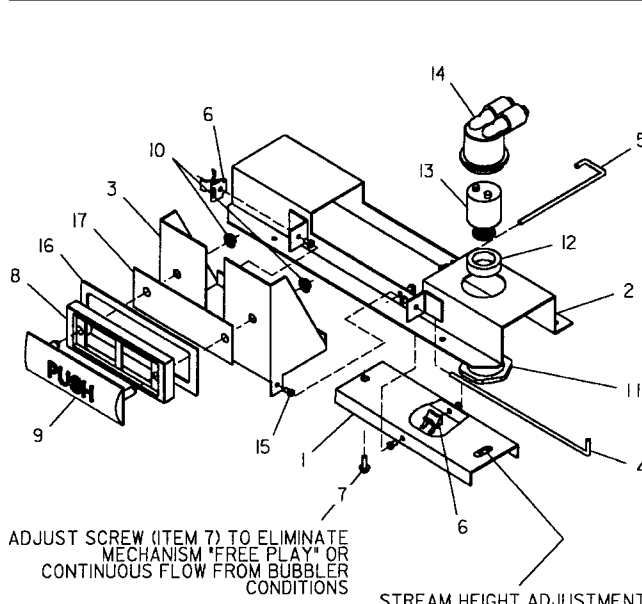

Figure 15 – Push Bar Mechanism

Item	Part No.	Description
1	26901C	Push Lever
2	26935C	Mounting Bracket Assy
3	27237C	Bracket – Pushbar
4	75517C	Lever Rod
5	70378C	Pushbar Rod
6	75555C	Spring Clip
7	75504C	Screw - #10-24 x .38 PHMS
8	55859C	Pushbar – Side & Front
9	101514331640	Pushbar Insert
10	111411743620	Nut – 1/4 Self Thread
11	40045C	Regulator Hex Nut
12	15005C	Regulator Retaining Nut
13	61313C	Regulator
14	50986C	Regulator Holder
15	50198C	Snap Bushing
16	55899C	Pad – Window Filler
17	27073C	Backing Plate



Figure 16 – Lower Panel Installation

12. Replace bottom access panel to fountain basin using screws provided. Tighten securely.

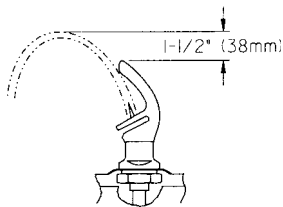

Figure 17 – Stream Height

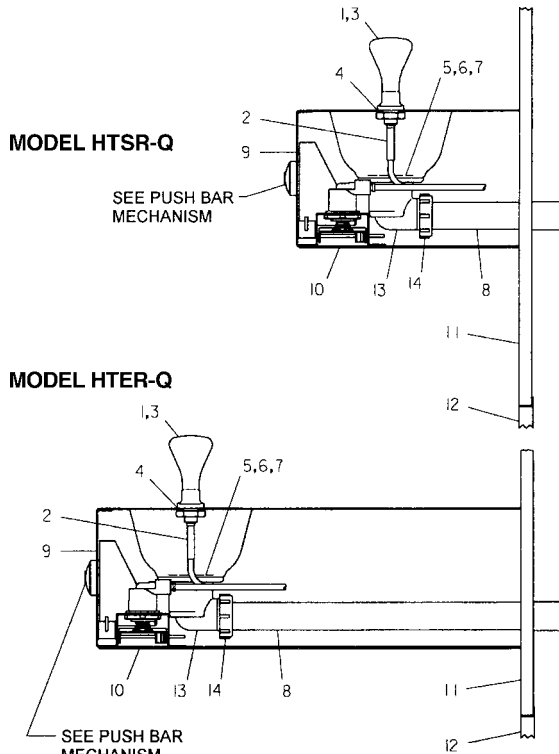

Figure 18 – Fountain Assembly - Side View

**Halsey Taylor**  
 2222 CAMDEN COURT  
 OAK BROOK, IL 60523  
 630.574.3500  
 PRINTED IN U.S.A.

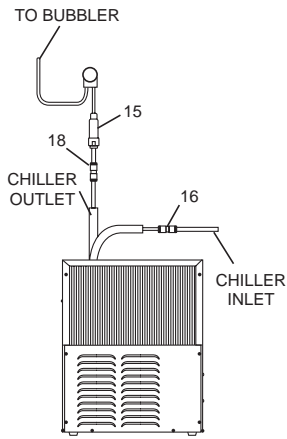

Figure 19 – HTER-Q/HTSR-Q Tube Routing

### TROUBLESHOOTING & MAINTENANCE

**Orifice Assembly:** Mineral deposits on orifice can cause water flow to spurt or not regulate. Mineral deposits may be removed from the orifice by poking with a small round file not over 1/8" diameter, or using a small diameter wire.

**CAUTION:** DO NOT file or cut orifice material.

**Stream Regulator:** If orifice is clean, regulate flow as in Step 10 of the installation instructions. If replacement is necessary, see parts list for correct regulator part number.

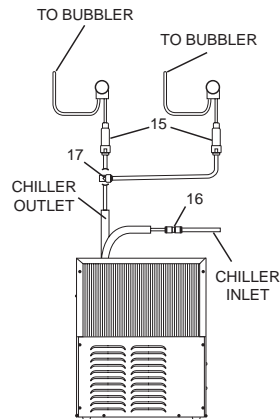
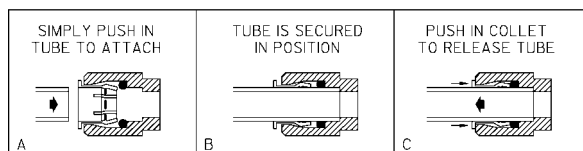

Figure 20 – HTSER-Q/HTSR-Q Tube Routing

**Actuation of Quick Connect Water Fittings:** Cooler is provided with lead-free connectors which utilize an o-ring water seal. To remove tubing from the fitting, relieve water pressure, push in on the gray collar while pulling on the tubing. (See Figure 21) To insert tubing, push tube straight into fitting until it reaches a positive stop (approximately 3/4").

#### OPERATION OF QUICK CONNECT FITTINGS



PUSHING TUBE IN BEFORE PULLING IT OUT HELPS TO RELEASE TUBE

Figure 21 – Quick Connect Fittings