

Halsey Taylor Owners Manual

Refrigerated Fountains with Back Panel

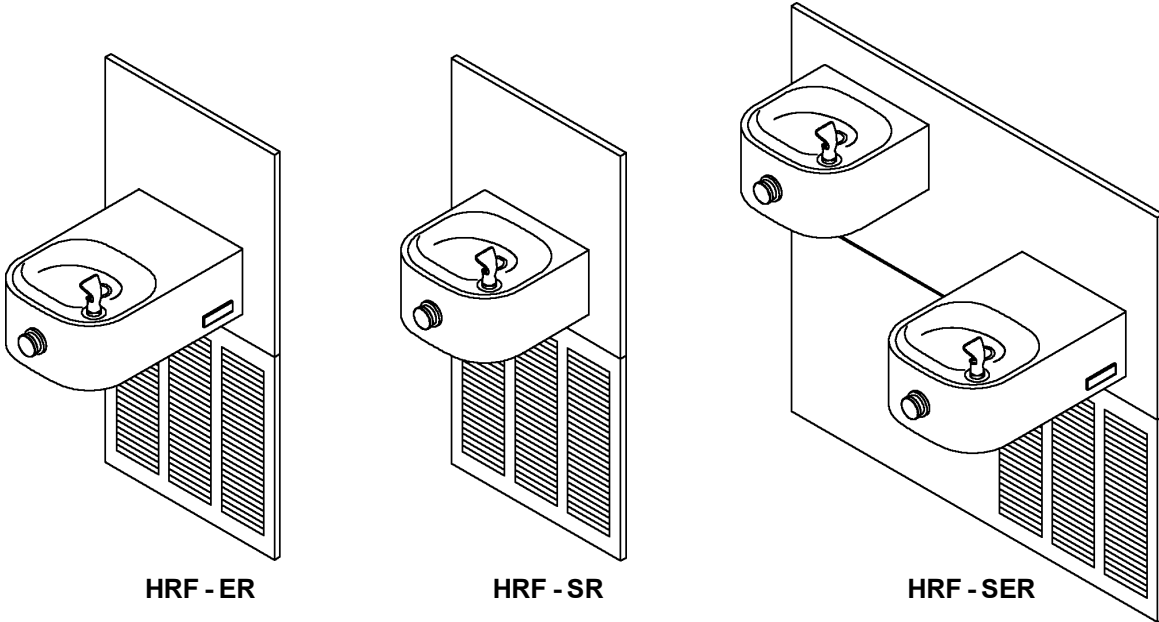

Installer

To assure you install this model easily and correctly, PLEASE READ THESE SIMPLE INSTRUCTIONS BEFORE STARTING THE INSTALLATION. CHECK YOUR INSTALLATION FOR COMPLIANCE WITH PLUMBING, ELECTRICAL AND OTHER APPLICABLE CODES. After installation, leave these instructions inside the fountain for future reference.

IMPORTANT

ALL SERVICE TO BE PERFORMED BY AN AUTHORIZED SERVICE PERSON

IMPORTANT! INSTALLER PLEASE NOTE.

THE GROUNDING OF ELECTRICAL EQUIPMENT SUCH AS TELEPHONE, COMPUTERS, ETC. TO WATER LINES IS A COMMON PROCEDURE. THIS GROUNDING MAY BE IN THE BUILDING OR MAY OCCUR AWAY FROM THE BUILDING. THIS GROUNDING CAN CAUSE ELECTRICAL FEEDBACK INTO A FOUNTAIN, CREATING AN ELECTROLYSIS WHICH CAUSES A METALLIC TASTE OR AN INCREASE IN THE METAL CONTENT OF THE WATER. THIS CONDITION IS AVOIDABLE BY USING THE PROPER MATERIALS AS INDICATED. ANY DRAIN FITTINGS PROVIDED BY THE INSTALLER SHOULD BE MADE OF PLASTIC TO ELECTRICALLY ISOLATE THE FOUNTAIN FROM THE BUILDING PLUMBING SYSTEM.

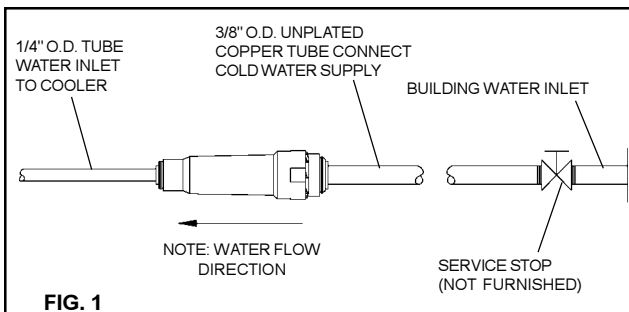

FIG. 1

OPERATION OF QUICK CONNECT FITTINGS

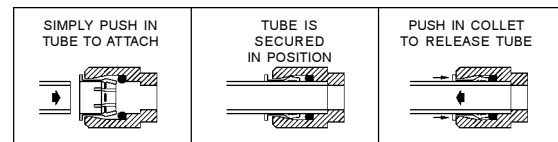

FIG. 2

PUSHING TUBE IN BEFORE PULLING IT OUT HELPS TO RELEASE TUBE

HRF-ER/SR ROUGH-IN

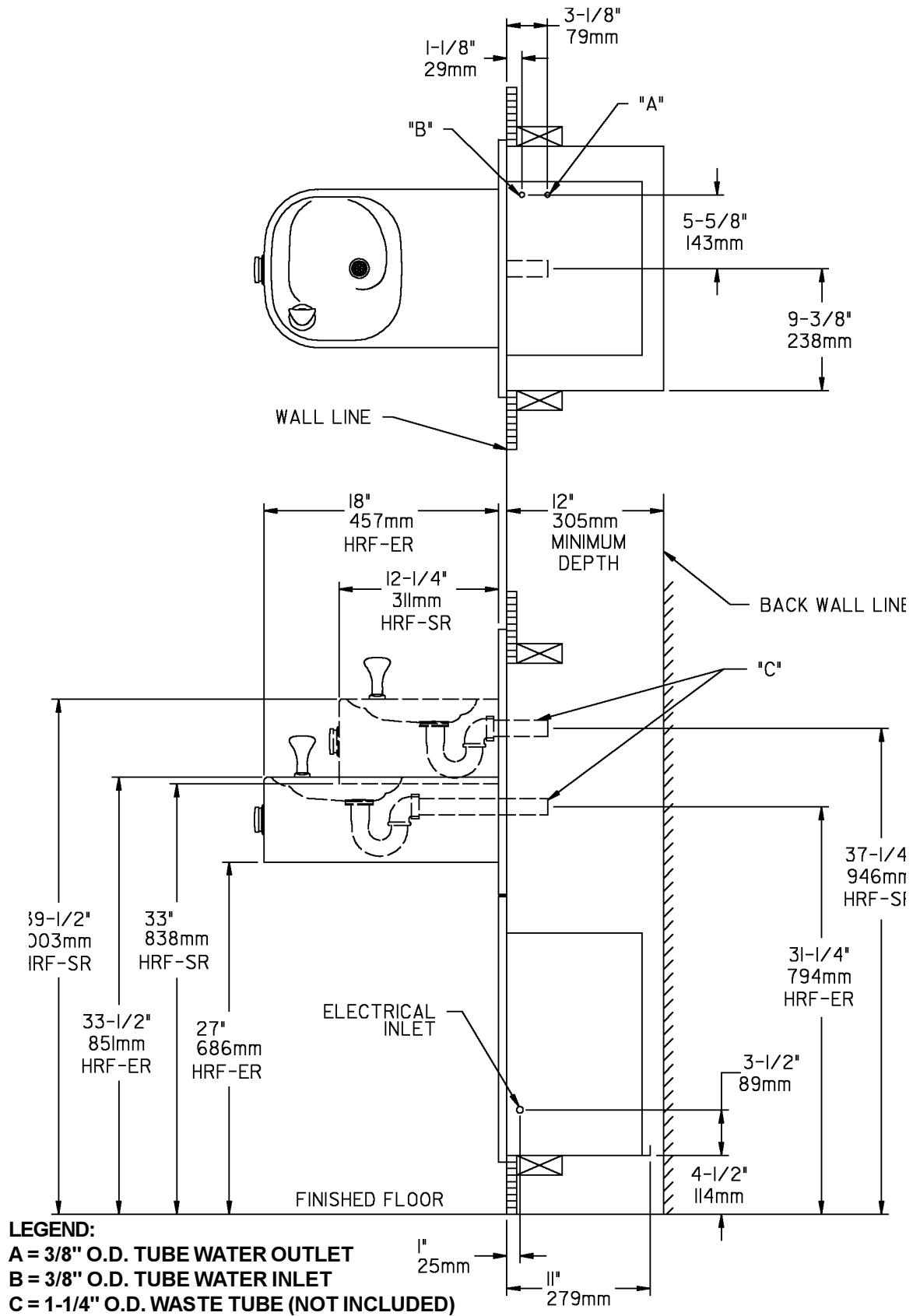

FIG. 3

HRF-SER ROUGH-IN

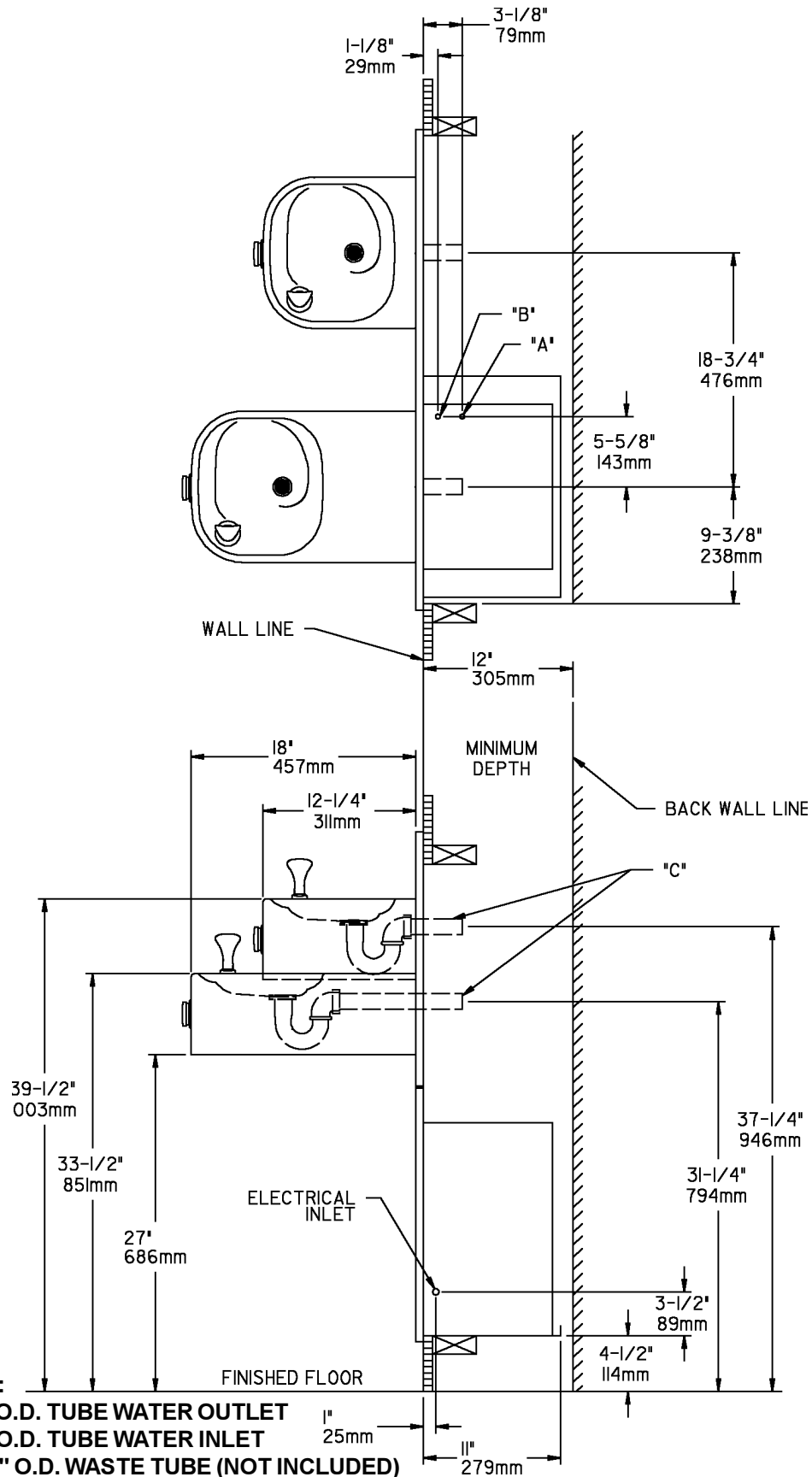

FIG. 4

| PARTS LIST | | |
|------------|----------|----------------------------------|
| ITEM NO. | PART NO. | DESCRIPTION |
| 1 | LK464 | Drain |
| | LK464AG | Drain-Aztec Gold |
| 2 | 15005C | Retaining Nut |
| 3 | 40038C | Strainer |
| | 45364C | Strainer-Aztec Gold |
| 4 | 40619C | Tailpipe Ferrule |
| | 45360C | Tailpipe Ferrule-Aztec Gold |
| 5 | 45662C | Push Button |
| | 45408C | Push Button-Aztec Gold |
| 6 | 45663C | Push Button Sleeve |
| | 45411C | Push Button Sleeve-Aztec Gold |
| 7 | 50986C | Regulator Holder |
| 8 | 51544C | Bubbler |
| | 45396C | Bubbler-Aztec Gold |
| 9 | 61313C | Regulator |
| 10 | 70022C | Setscrew #6-32 x .31" |
| 11 | 70426C | Screw #8-32 x .25" |
| 12 | 55996C | Strainer |
| 13 | 55001035 | Fountain Arm-Short |
| | 27571C | Fountain Arm-Short Aztec Gold |
| | 55001038 | Fountain Arm-Extended |
| | 27573C | Fountain Arm-Extended Aztec Gold |
| 14 | 55000661 | Bottom Cover Plate-Short |
| | 55000665 | Bottom Cover Plate-Extended |
| 15 | 26839C | Back Panel HRF-SER |
| | 27542C | Back Panel HRF-SER Aztec Gold |
| | 26837C | Back Panel HRF-ER/SR |
| | 27539C | Back Panel HRF-ER/SR Aztec Gold |
| 16 | 40045C | Hex Nut |
| 17 | 70055C | Speed Nut |
| 18 | 27057C | Bracket-Regulator Mounting |
| 19 | 27026C | Lower Panel HRF-SER |
| | 27580C | Lower Panel HRF-SER Aztec Gold |
| | 26833C | Lower Panel HRF-ER/SR |
| | 27578C | Lower Panel HRF-ER/SR Aztec Gold |
| 20 | 70745C | Union - 3/8" x 1/4" |
| 21 | 70870C | Union - 3/8" |
| 22 | 70852C | Tee - 3/8" |
| 23 | 15008C | Assy-Bubbler Nipple |
| 24 | 55994C | Tube-Poly 1/4 x .040 Wall |

HRF - ER/SR/SER COOLER INSTALLATION

- 1. Install remote chiller.** Remove front panel of chiller. Remove and discard cardboard inner pack from between compressor and side panel. Slide chiller onto the shelf and position it to the left within the guides on the shelf.
NOTE: Building construction must allow for adequate air flow on both sides, top, and back of chiller. A minimum of 4" (102mm) on both sides and top is required. See chiller instructions for additional instructions.
- 2. Make water supply connections.** Attach an unplated copper water inlet line and a service stop (not provided) to the chiller. Inlet port is marked on the chiller (3/8" O.D. copper tube). Bend the copper tube (provided) at an appropriate length from chiller to opening in frame. Install a 3/8" O.D. tube tee fitting (provided) on the marked chiller outlet port. Turn on the water supply and flush the line thoroughly.
- 3. Hang the upper panel on the mounting frame hanger.** Align holes in the panel with the holes in the mounting frame. Be sure that panel is engaged with hanger at top of frame before releasing it.
- 4. Install fountain.** Remove access cover plate on underside of fountains and save the screws. Mount the fountains to the upper panel and the wall frame with (4) 5/16" x 3/4" (19mm) long bolts and nuts (provided). Tighten securely.
NOTE: The short fountain should be mounted to the upper left hand side of the panel.
- 5. Remove elbow from end of p-trap** and attach it to drain tube. Re-attach elbow to p-trap and cut waste tube to required length using plumbing hardware and trap as a guide.
- 6. Make connection between remote chiller outlet tube and fountain strainer.** Insert the water inlet line into inlet side of strainer by pushing it in until it reaches a positive stop, approximately 3/4" (19mm). Turn on water supply and check for leaks. **DO NOT SOLDER TUBES INSERTED INTO THE STRAINER AS DAMAGE TO THE O-RINGS MAY RESULT.**
- 7. These products are designed to operate on 20-105 PSIG supply line pressure.** If inlet pressure is above 105 PSIG, a pressure regulator must be installed in the supply line. Any damage caused by reason of connecting these products to supply line pressures lower than 20 PSIG or higher than 105 PSIG is not covered by warranty.
- 8. Make electrical connections to the chiller.** See chiller instructions.
- 9. Check stream height from bubbler.** Stream height is factory set at 45-50 PSI. If supply pressure varies greatly from this, remove items 5 & 6 and adjust the screw on regulator (item 9). Clockwise adjustment will raise stream height and counter-clockwise will lower stream height. For best adjustment stream height should be approximately 1-1/2" (38mm) above the bubbler guard. (See Figure 6)
- 10. Mount lower panel.** Loosen the (2) #10-24 x 5/8" (16mm) screws at frame bottom lip. Slide upper tongue of lower panel under lower edge of already installed upper panel. Tighten previously loosened screws securely.
- 11. Replace bottom access panel to fountain basin** using screws provided. Tighten securely.

TROUBLE SHOOTING & MAINTENANCE

Orifice Assy: Mineral deposits on orifice can cause water flow to spurt or not regulate. Mineral deposits may be removed from the orifice with a small round file not over 1/8" diameter or small diameter wire.
CAUTION: DO NOT file or cut orifice material.

Stream Regulator: If orifice is clean, regulate flow as in "START UP" instructions. If replacement is necessary, see parts list for correct regulator part number.

Actuation of Quick Connect Water Fittings: Cooler is provided with lead-free connectors which utilize an o-ring water seal. To remove tubing from the fitting, relieve water pressure, push in on the gray collar while pulling on the tubing. (see Fig. 2) To insert tubing, push tube straight into fitting until it reaches a positive stop, approximately 3/4".

CAUTION: Cleaning of Aztec Gold Models requires special care. Outer surfaces must be cleaned with mild detergent or a mixture of vinegar and water only, rinsed and wiped dry. Abrasive and acidic cleaners may eventually damage the Aztec Gold finish.

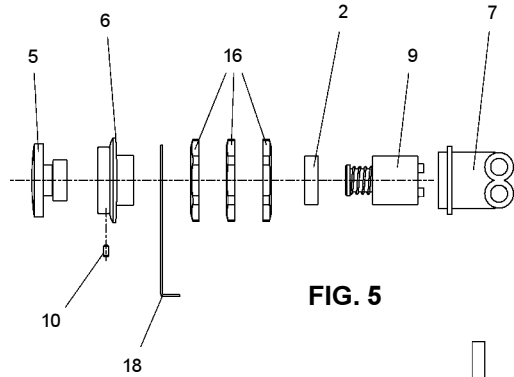

FIG. 5

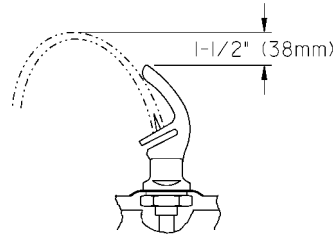
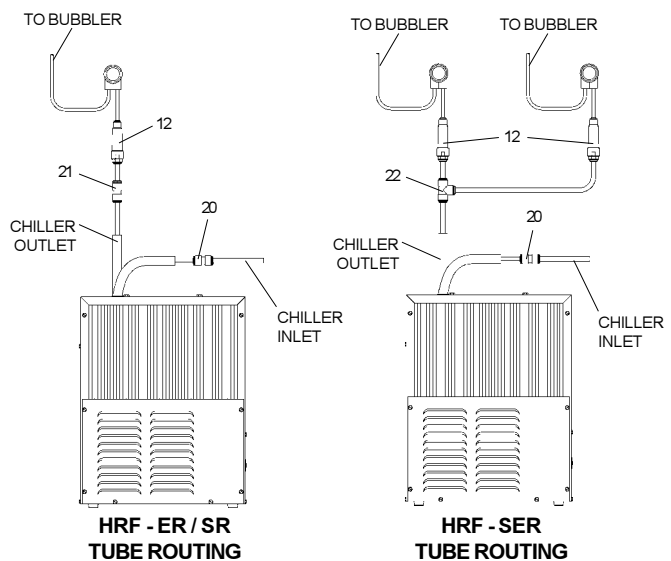
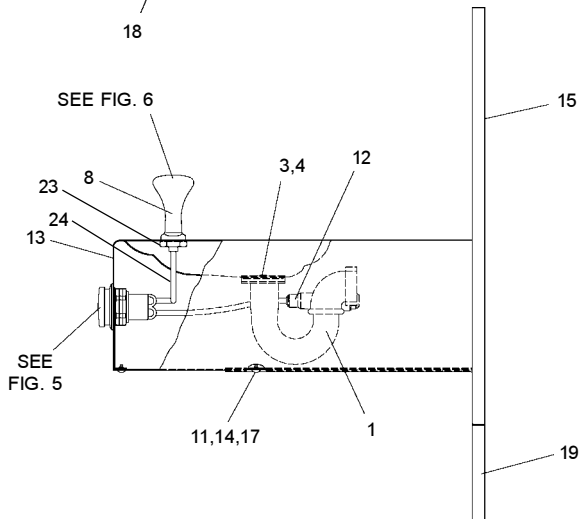

FIG. 6



HRF - ER / SR
TUBE ROUTING

HRF - SER
TUBE ROUTING

Halsey Taylor
2222 CAMDEN COURT
OAK BROOK, IL 60523
630.574.3500
PRINTED IN U.S.A.

FOR PARTS, CONTACT YOUR LOCAL DISTRIBUTOR OR CALL 1.800.323.0620