

# Halsey Taylor Owners Manual

## Refrigerated Marblyte Fountains with Back Panel

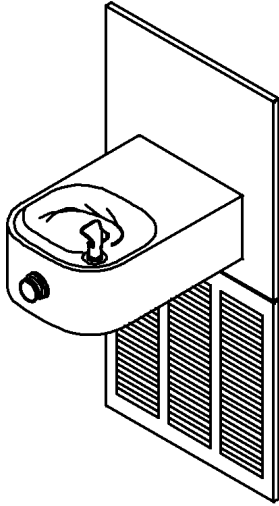

HRFG - ER

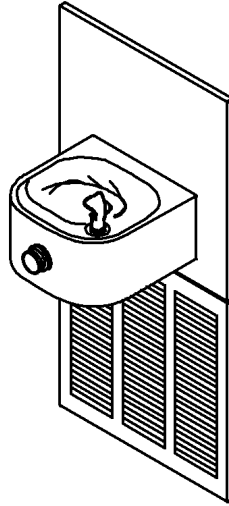

HRFG - SR

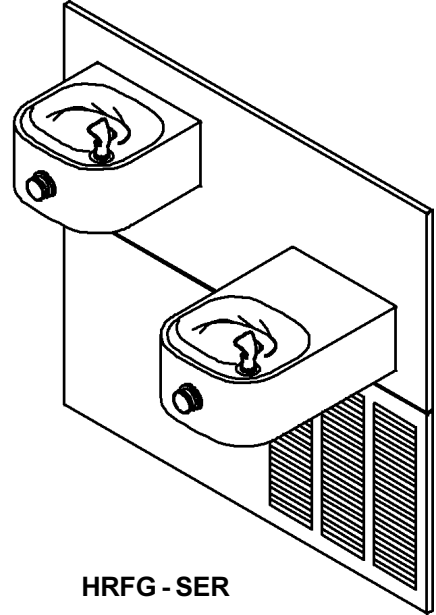

HRFG - SER

### Installer

To assure you install this model easily and correctly, PLEASE READ THESE SIMPLE INSTRUCTIONS BEFORE STARTING THE INSTALLATION. CHECK YOUR INSTALLATION FOR COMPLIANCE WITH PLUMBING, ELECTRICAL AND OTHER APPLICABLE CODES. After installation, leave these instructions inside the fountain for future reference.

### IMPORTANT

ALL SERVICE TO BE PERFORMED BY AN AUTHORIZED SERVICE PERSON

### IMPORTANT! INSTALLER PLEASE NOTE.

THE GROUNDING OF ELECTRICAL EQUIPMENT SUCH AS TELEPHONE, COMPUTERS, ETC. TO WATER LINES IS A COMMON PROCEDURE. THIS GROUNDING MAY BE IN THE BUILDING OR MAY OCCUR AWAY FROM THE BUILDING. THIS GROUNDING CAN CAUSE ELECTRICAL FEEDBACK INTO A FOUNTAIN, CREATING AN ELECTROLYSIS WHICH CAUSES A METALLIC TASTE OR AN INCREASE IN THE METAL CONTENT OF THE WATER. THIS CONDITION IS AVOIDABLE BY USING THE PROPER MATERIALS AS INDICATED. ANY DRAIN FITTINGS PROVIDED BY THE INSTALLER SHOULD BE MADE OF PLASTIC TO ELECTRICALLY ISOLATE THE FOUNTAIN FROM THE BUILDING PLUMBING SYSTEM.

**HRFG-ER/SR ROUGH-IN**

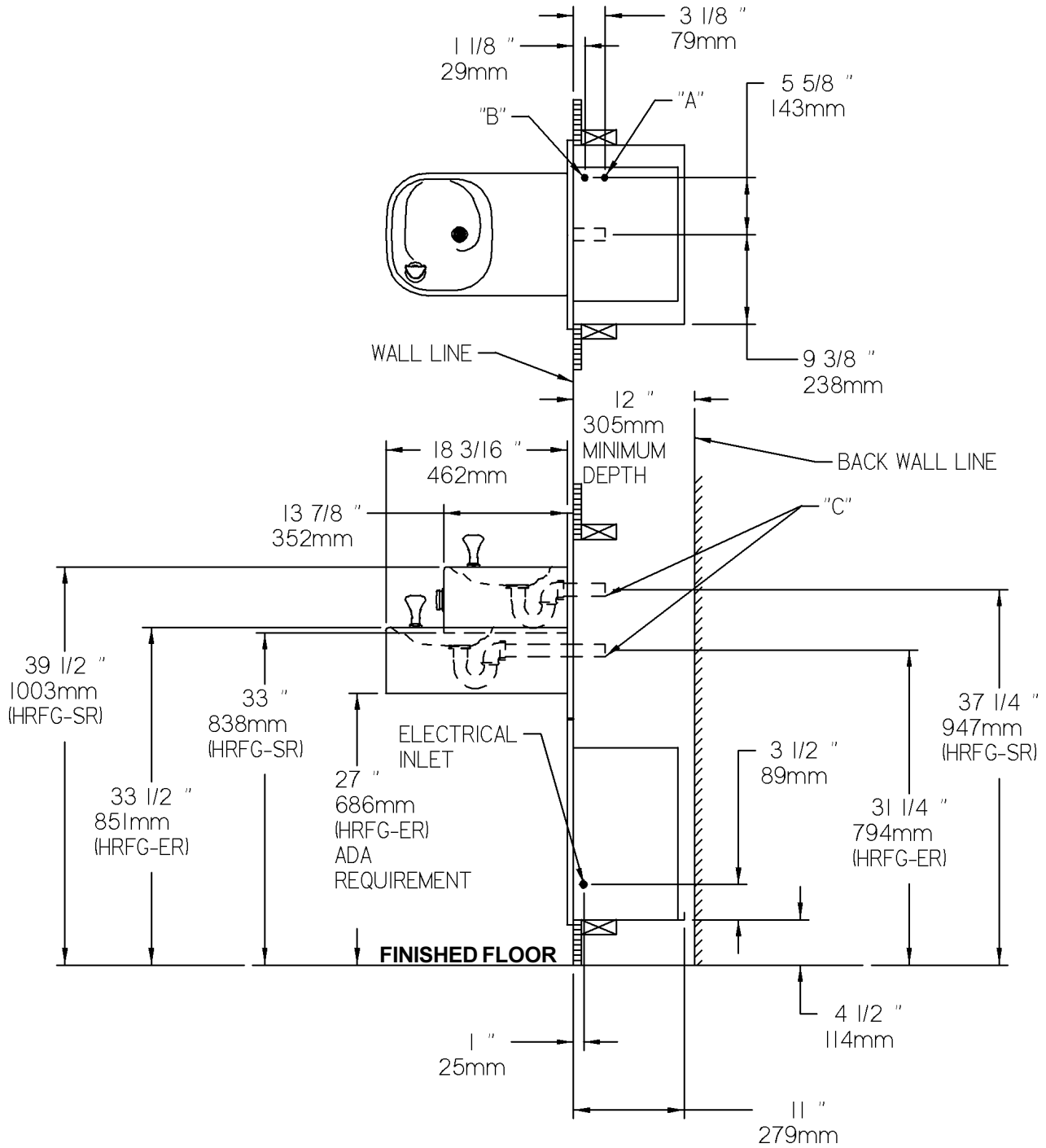

**LEGEND:**  
**A = 1/4" O.D. TUBE WATER OUTLET**  
**B = 3/8" O.D. TUBE WATER INLET**  
**C = 1-1/4" O.D. WASTE TUBE (NOT INCLUDED)**

**FIG. 1**

**HRFG-SER ROUGH-IN**

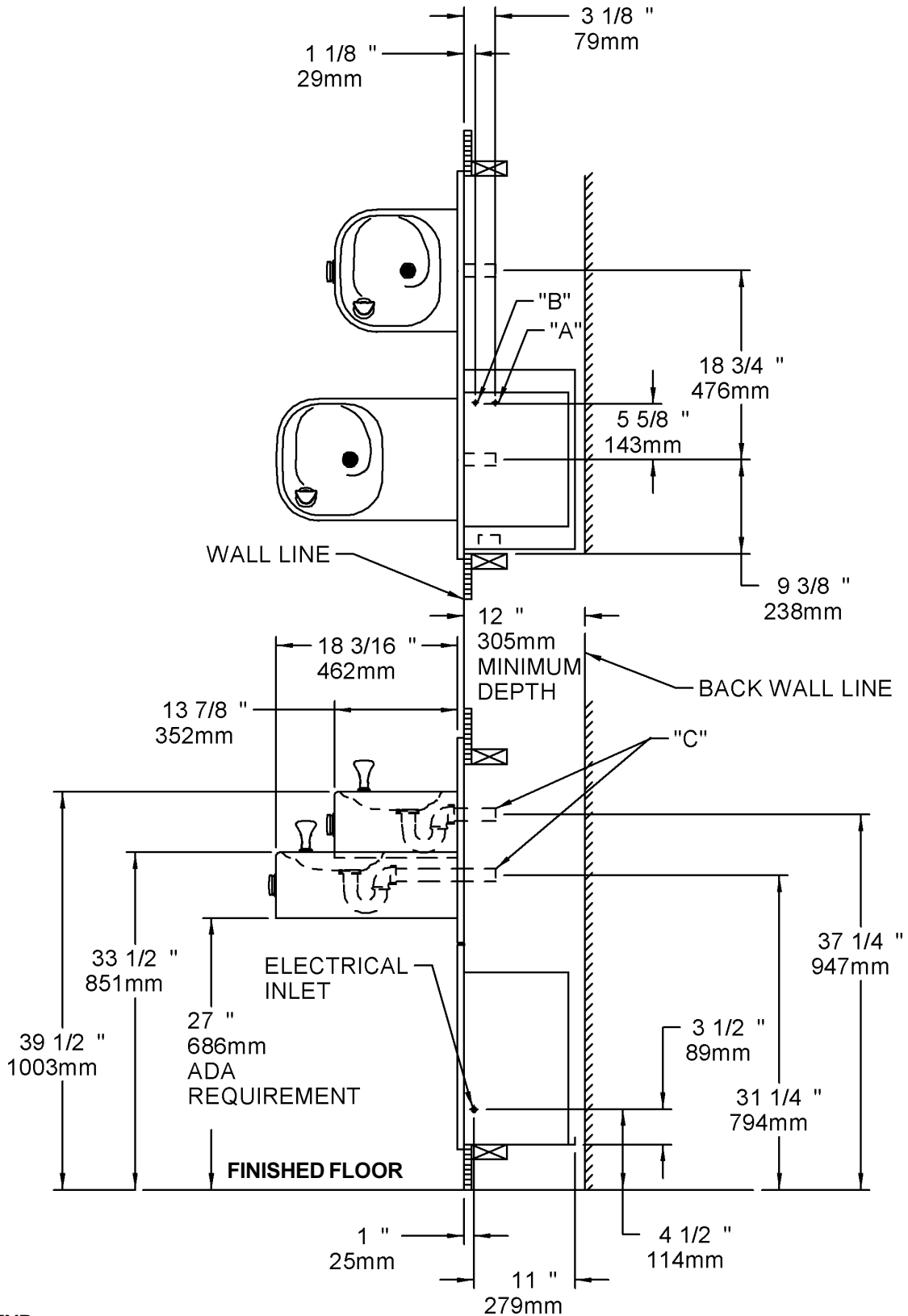

**LEGEND:**  
**A = 1/4" O.D. TUBE WATER OUTLET**  
**B = 3/8" O.D. TUBE WATER INLET**  
**C = 1-1/4" O.D. WASTE TUBE (NOT INCLUDED)**

**FIG. 2**

**INSTALLATION INSTRUCTIONS**

1. **Install remote chiller.** Remove front panel of chiller. **Remove and discard cardboard inner pack from between compressor and side panel.** Slide chiller onto the shelf and position it to the left within the guides on the shelf.  
**NOTE:** Building construction must allow for adequate air flow on both sides, top, and back of chiller. A minimum of 4" (102mm) on both sides and top is required. See chiller instructions for additional instructions.
2. **Make water supply connections.** The inlet port is marked on the chiller (1/4" O.D. copper tube). Bend the copper tube (provided) at an appropriate length from chiller to opening in frame. Install the in-line strainer (provided with chiller) by pushing it in until it reaches a positive stop, approximately 3/4" (19mm) on the marked chiller inlet port. Attach an unplated and deburred copper water inlet line and a service stop (not provided) to the in-line strainer. Turn on the water supply and flush the line thoroughly. **DO NOT SOLDER TUBES WHILE INSERTED INTO THE STRAINER AS DAMAGE TO THE O-RINGS MAY RESULT.**
3. **Hang the upper panel on the mounting frame hanger.** Align holes in the panel with the holes in the mounting frame. Be sure that panel is engaged with hanger at top of frame before releasing it.
4. **Install fountain.** Remove access cover plate on underside of fountains and save the screws. Mount the fountains to the upper panel and the wall frame with (4) 5/16" x 1-1/4" (32mm) long bolts, washers, and nuts. Tighten securely, but do not overtighten. Over tightening will crack the Marblyte Fountain.  
**NOTE:** The short fountain should be mounted to the upper left hand side of the panel.
5. **Remove elbow from end of p-trap and attach it to drain tube.** Re-attach elbow to p-trap and cut waste tube to required length using plumbing hardware and trap as a guide.
6. **Make connection between remote chiller outlet tube and fountain(s).** Outlet port is marked on the chiller (1/4" O.D. copper tube). Install a 1/4" union/tee (provided) on the marked chiller outlet port. Insert the 1/4" poly tubing coming from the fountain(s) into the union/tee. Turn on water supply and check for leaks. **DO NOT SOLDER TUBES WHILE INSERTED INTO THE STRAINER AS DAMAGE TO THE O-RINGS MAY RESULT.** (See figure 8 or 9).
7. **These products are designed** to operate on 20-105 PSIG supply line pressure. If inlet pressure is above 105 PSIG, a pressure regulator must be installed in the supply line. Any damage caused by reason of connecting these products to supply line pressures lower than 20 PSIG or higher than 105 PSIG is not covered by warranty.
8. **Make electrical connections to the chiller.** See chiller instructions.
9. **Check stream height from bubbler.** Stream height is factory set at 35-40 PSI. If supply pressure varies greatly from this, remove items 5 & 13 (See Figure 6, Page 6) by loosening set screw (item 10) and adjust the screw on regulator (item 9). Clockwise adjustment will raise stream height and counter-clockwise adjustment will lower stream height. For best adjustment stream height should be approximately 1-1/2" (38mm) above the bubbler guard (See Figure 5, Page 5).
10. **Mount lower panel.** Loosen the (2) #10-24 x 5/8" (16mm) screws at frame bottom lip. Slide upper tongue of lower panel under lower edge of already installed upper panel. Tighten previously loosened screws securely.
11. **Replace bottom access panel** to fountain basin using screws provided. Tighten securely.

**Care and Maintenance of Halsey Taylor Marblyte Fountains**

Marblyte provides an extremely durable, nonporous surface which resists staining. Care is very simple. Routine cleaning with a soft sponge or cloth, or with water or non-abrasive aerosol foam cleaner, is all that is normally needed to give many years of trouble free service. Cleaners left standing on the fountain surface can dull the surface finish. Be certain to rinse all cleaning agents completely and polish with a soft cloth.

Harsh abrasive cleaners are not required and should not be used.

Mild abrasives such as liquid automotive cleaning compound or baking soda paste will remove simple scratches and stains. Cigarette burns can normally be removed without noticeable effect. Deeper scratches or gouges can be corrected with fine grit sandpaper (240 grit then 400 grit) or a green Scotchbrite pad.

To maintain or regain luster and make cleaning easier, periodic applications of automobile wax or like products will keep the finish looking like new.

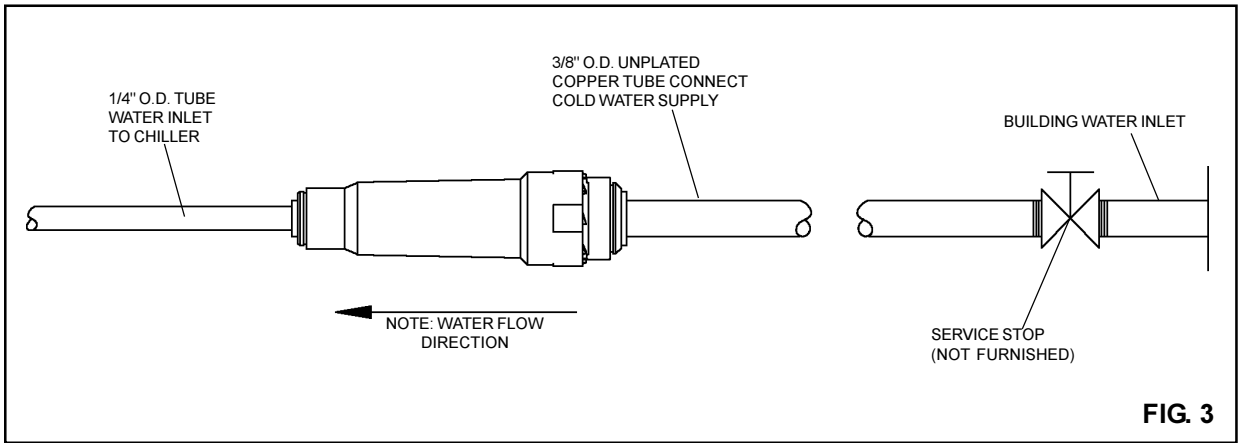

**OPERATION OF QUICK CONNECT FITTINGS**

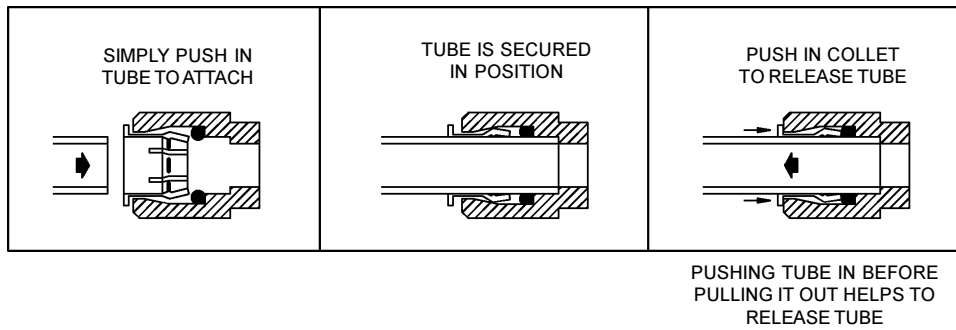

**FIG. 4**

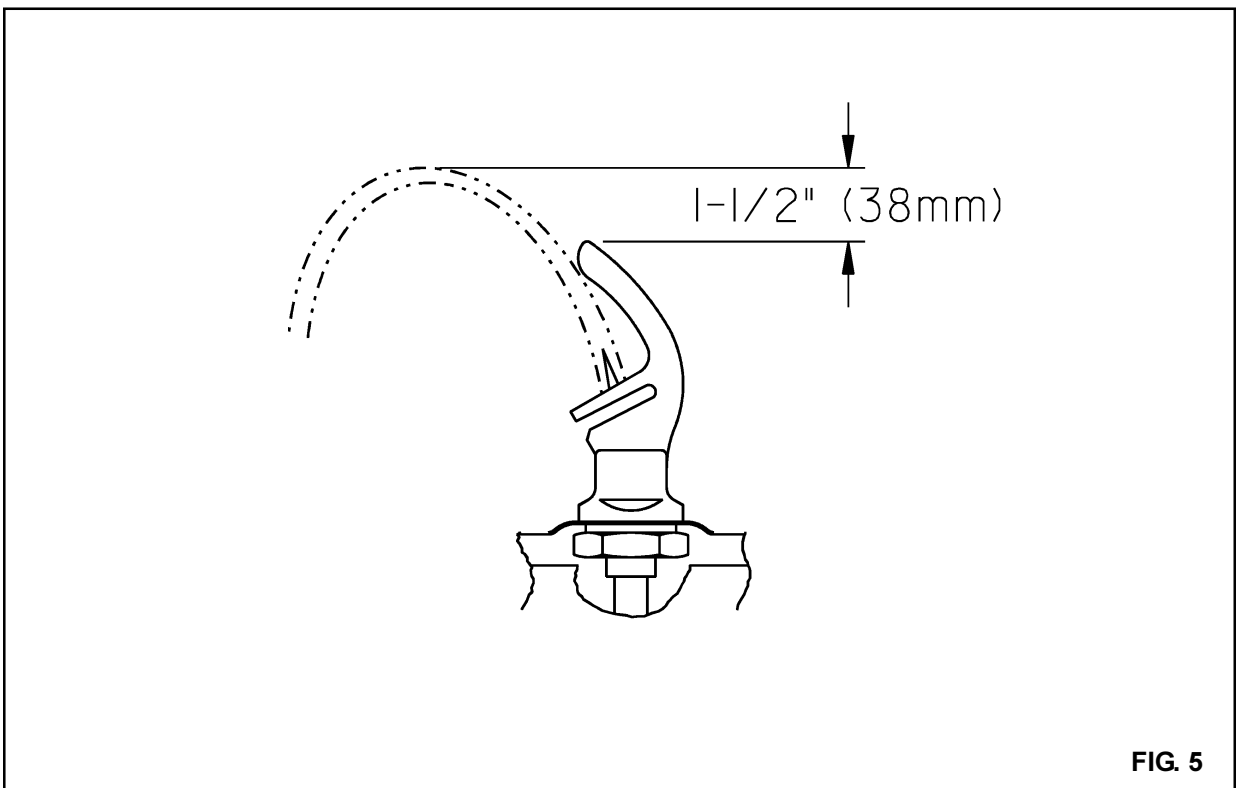

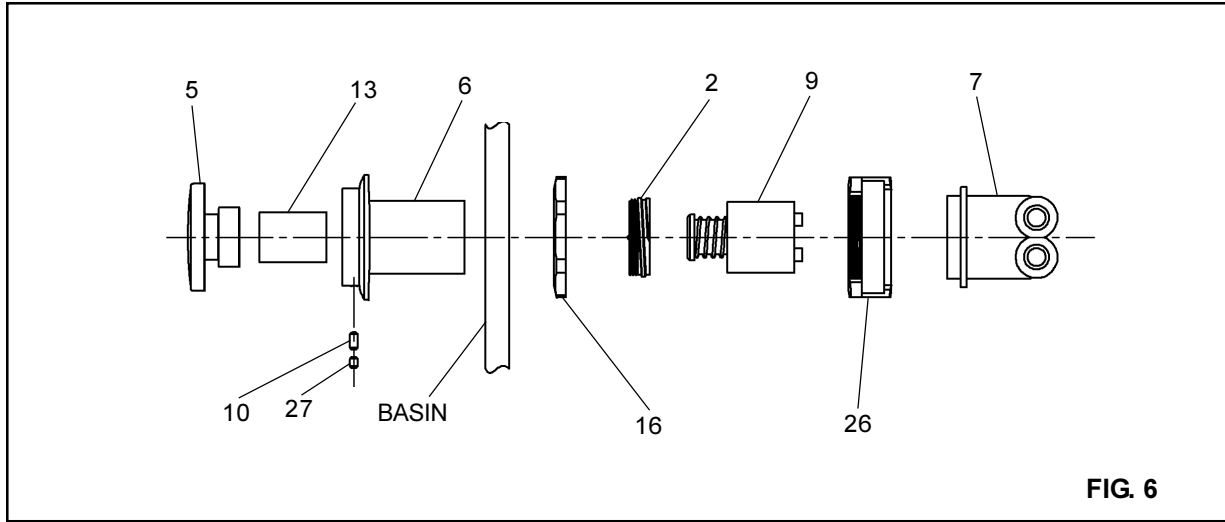

FIG. 6

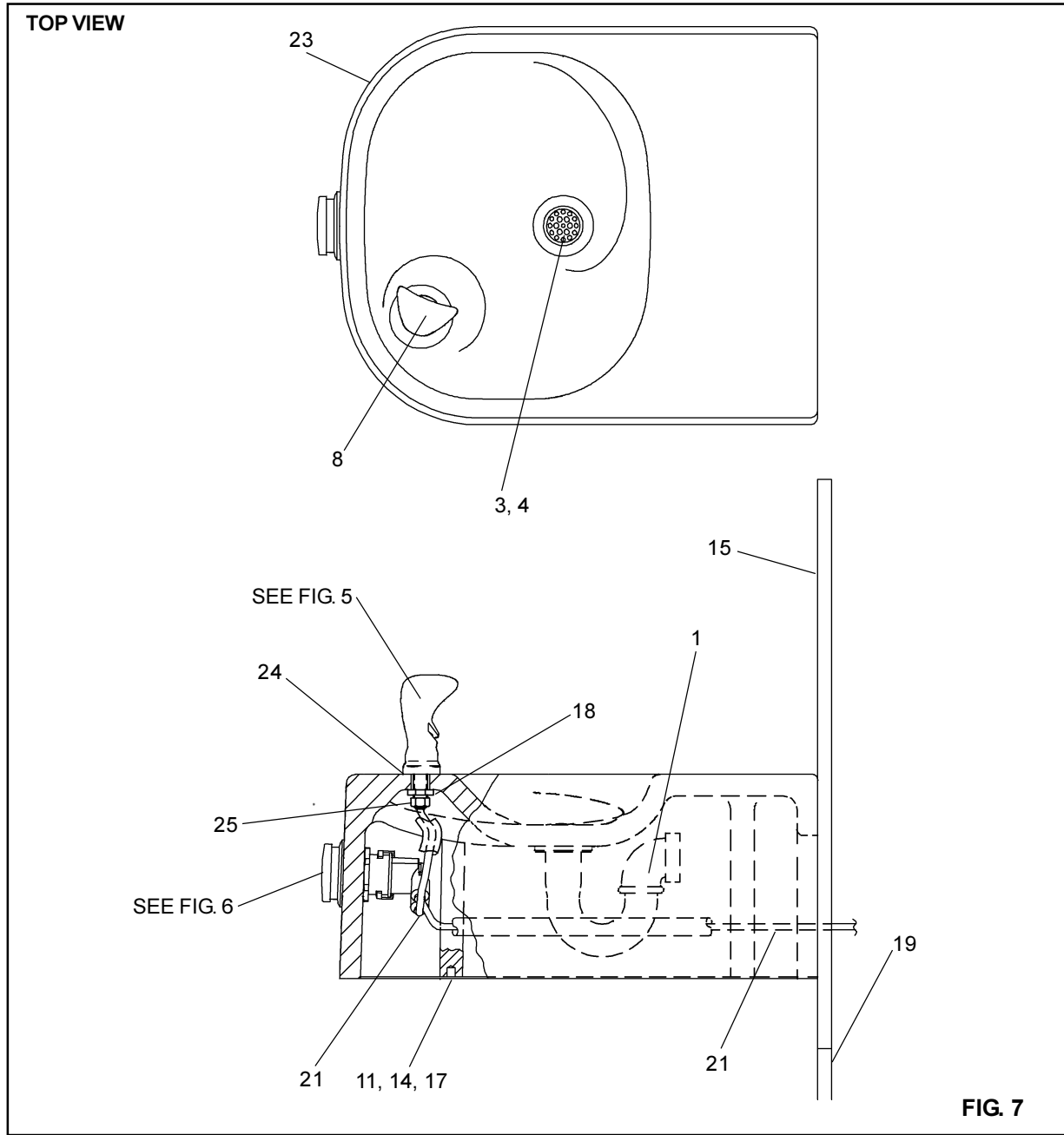
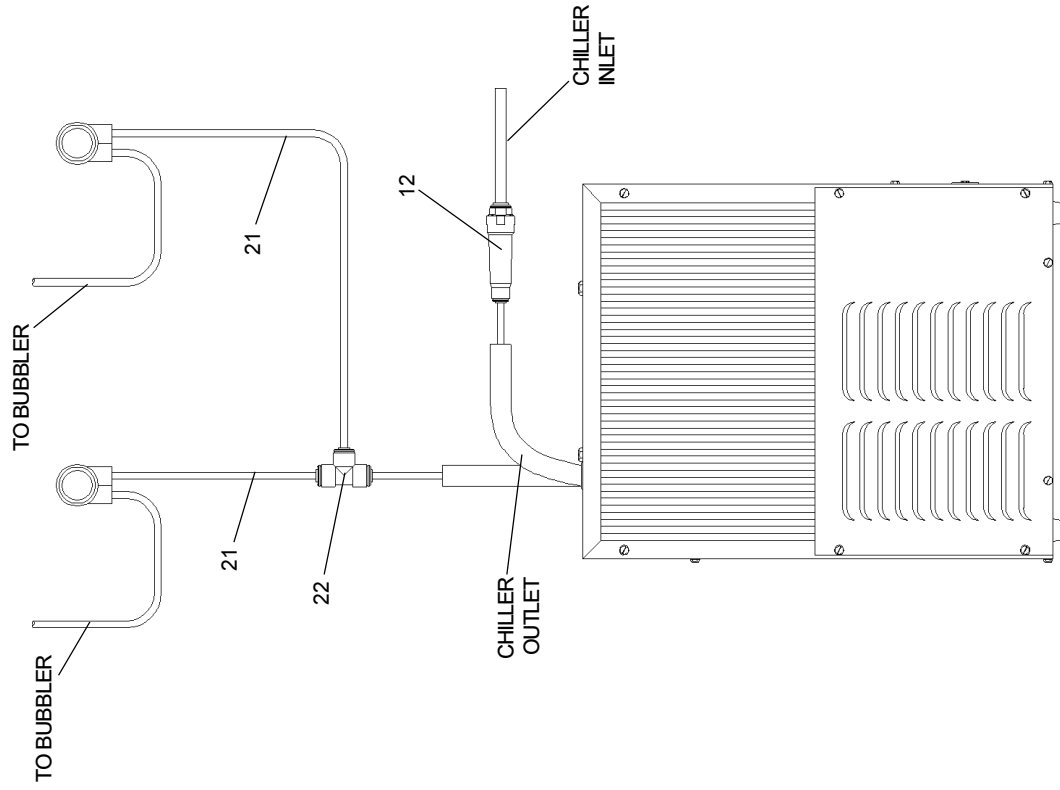
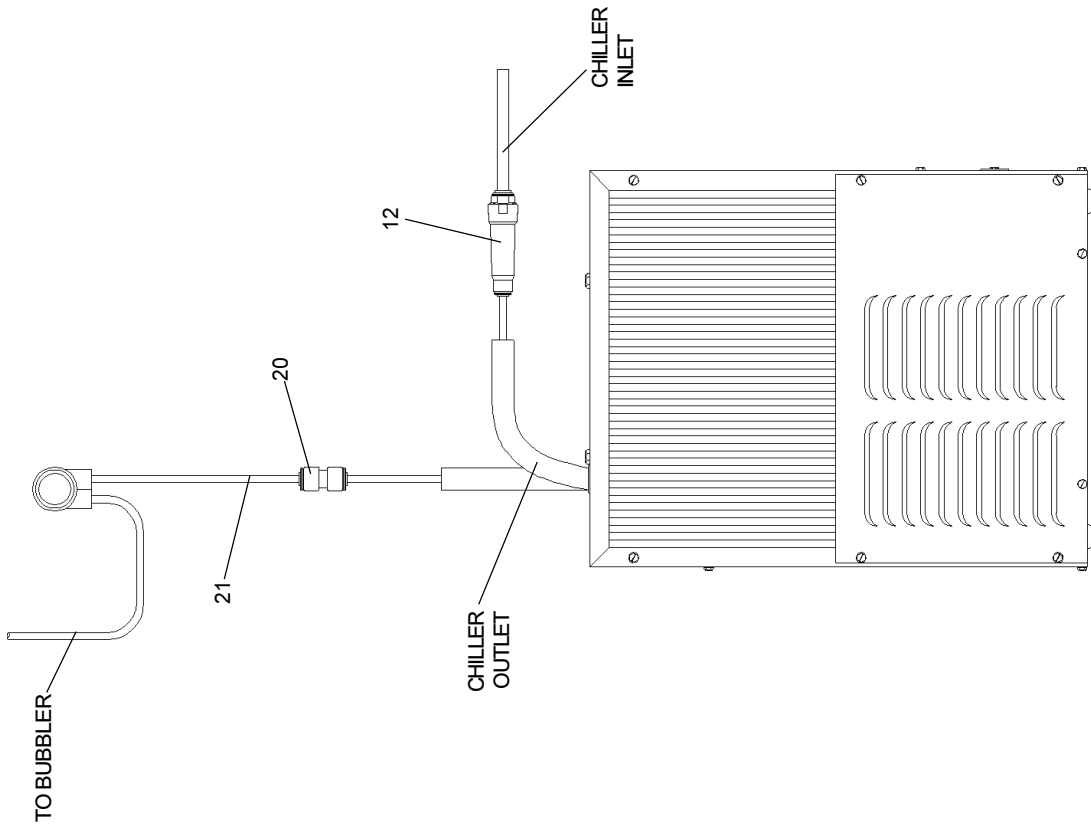

FIG. 7



HRFG - SER  
TUBE ROUTING

FIG. 8



HRFG - ER / SR  
TUBE ROUTING

FIG. 9

PARTS LIST		
ITEM NO.	PART NO.	DESCRIPTION
1	LK464	Drain
2	15005C	Retaining Nut
3	40038C	Strainer
4	40619C	Tailpipe Ferrule
5	45662C	Push Button
6	45738C	Push Button Sleeve
7	50986C	Regulator Holder
8	51544C	Bubbler
9	61313C	Regulator
10	70022C	Screw #6-32 x .31" Set
11	112627543890	Screw #10-24 x 1/2 PH TR HD-Z
12	55996C	Strainer
13	56087C	Push Button - Extension
14	27201C	Bottom Cover Plate-Short
	27658C	Bottom Cover Plate-Extended
15	26839C	Back Panel HRF-SER
	26837C	Back Panel HRF-ER
	26835C	Back Panel HRF-SR
16	40045C	Hex Nut
17	75554C	Insert - Threaded
18	70012C	Bubbler Locknut
19	27026C	Lower Panel HRF-SER
	26833C	Lower Panel HRF-ER/SR
20	70683C	Union - 1/4"
21	56092C	Poly Tubing - Cut To Length
22	70682C	Tee - 1/4"
23	55969C	Fountain-Galaxy Gray(HRFG-S)
	56053C	Fountain-Galaxy Gray(HRFG-E)
	56025C	Fountain-Black(HRFG-S)
	56056C	Fountain-Black(HRFG-E)
24	100322740560	Gasket - Black
25	15029C	Nipple Assembly
26	45736C	Nut - Regulator Mounting
27	70023C	Screw #6-32 x .12" Set

### TROUBLE SHOOTING & MAINTENANCE

**Orifice Assy:** Mineral deposits on orifice can cause water flow to spurt or not regulate. Mineral deposits may be removed from the orifice with a small round file not over 1/8" diameter or small diameter wire.

**CAUTION: DO NOT** file or cut orifice material.

**Stream Regulator:** If orifice is free of material deposits, regulate flow as instructions on page 4(Step 9). If replacement is necessary, see parts list for correct regulator part number.

**Actuation of Quick Connect Water Fittings:** Cooler is provided with lead-free connectors which utilize an o-ring water seal. To remove tubing from the fitting, relieve water pressure, push in on the gray collar while pulling on the tubing.(see Fig.4, Page 5) To insert tubing, push tube straight into fitting until it reaches a positive stop, approximately 3/4".

**Halsey Taylor**

2222 CAMDEN COURT  
OAK BROOK, IL 60523  
630.574.3500

PRINTED IN U.S.A.

FOR PARTS, CONTACT YOUR LOCAL DISTRIBUTOR OR CALL 1.800.323.0620