

Halsey Taylor Owners Manual

Models: HOWC8-F-Q

USES HFC-134A REFRIGERANT

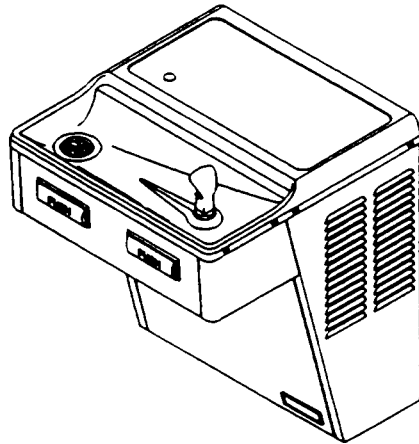

Installer

The HOWC series coolers are among the easiest to install Barrier-Free Models on the market today. To assure you install this model easily and correctly, PLEASE READ THESE SIMPLE INSTRUCTIONS BEFORE STARTING THE INSTALLATION. CHECK YOUR INSTALLATION FOR COMPLIANCE WITH PLUMBING, ELECTRICAL AND OTHER APPLICABLE CODES. After installation, leave these instructions inside the cooler for future use.

IMPORTANT

ALL SERVICE TO BE PERFORMED BY AN AUTHORIZED SERVICE PERSON

1. Insure proper ventilation by maintaining 6" (min.) clearance from cabinet louvers to wall on each side of cooler.
2. Water supply 3/8" IPS. Waste 1-1/4" IPS. Contractor to supply waste trap and service stop valve in accordance with local codes.
3. Connecting lines should be thoroughly flushed to remove all foreign matter before being connected to cooler. This cooler is manufactured in such a manner that it does not in any way cause taste, odor, color or sediment problems. If a taste, odor or sediment problem is prevalent, try installing our water filter module, Part No. 73-15242-51-550, on the supply line.
4. Electrical: Insure power supply is identical in voltage, cycle and phase to that specified on the cooler data plate. NEVER WIRE COMPRESSOR TO THE POWER SUPPLY. When cooler is installed outdoors, a Ground Fault Circuit Interrupter (GFCI) should be used.
5. For TROUBLE SHOOTING AND MAINTENANCE GUIDE, see page 4.
6. Halsey Taylor has glass fillers and glass filler plumbing kits specifically designed for use in your water cooler. Check local listings for a Halsey Taylor dealer near you.

WARNING: Warranty is voided if:

- The plumbing kit or glass filler is not specified for use by Halsey Taylor for this particular model.
- Installation is not made in accordance with current Halsey Taylor instructions.

WIRING DIAGRAM

This drawing is merely for illustrating the components of the electrical system.

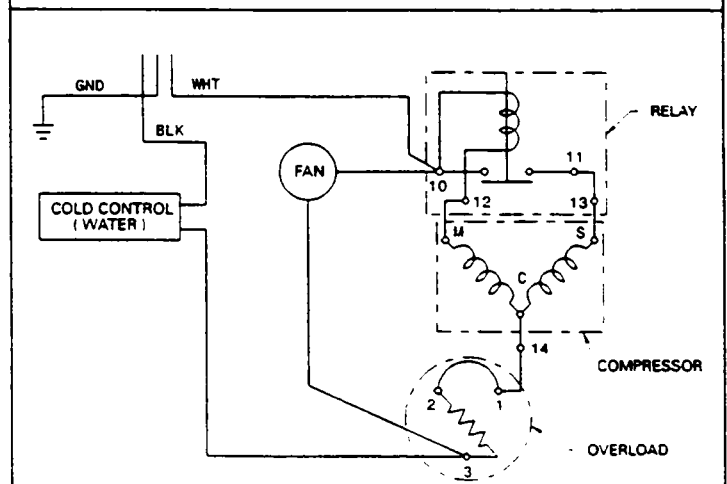

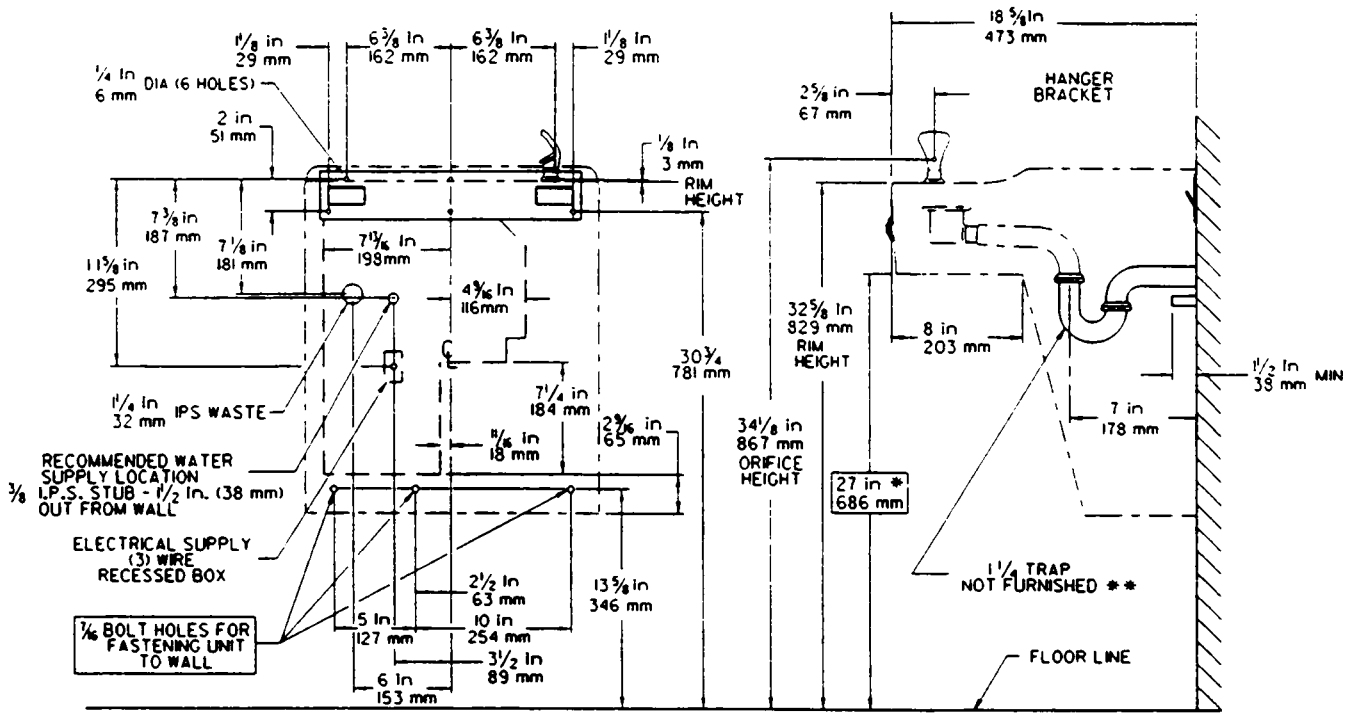

* ADA REQUIREMENT

** When replacing a Model "BFC" with a new unit Model "MAC", installer must cut 1-1/2 inches from length of cooler waste line before connecting to trap (see installation instruction No. 8).

FIG. 1

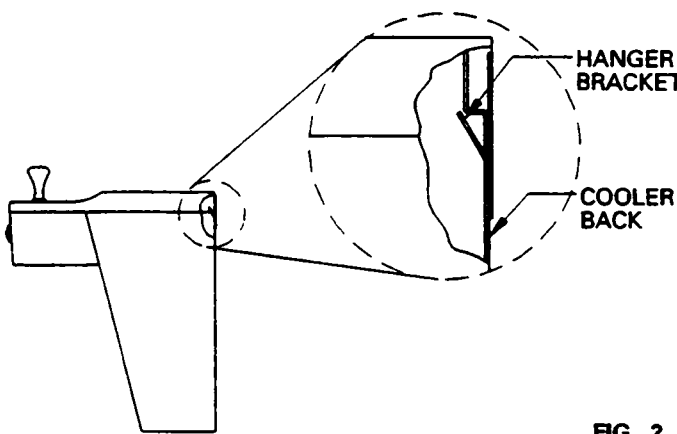

FIG. 2

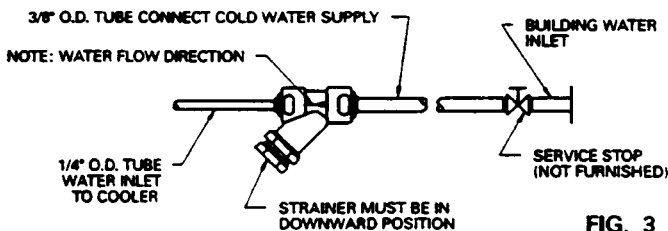

FIG. 3

HANGER BRACKET & TRAP INSTALLATION

1. Remove hanger bracket fastened to back of cooler by removing one (1) screw.
2. Mount the hanger bracket and trap as shown in Figure 1. **NOTE:** Hanger Bracket **MUST** be supported securely. Add fixture support carrier if wall will not provide adequate support.

IMPORTANT:

- 7 in. dimension from wall to centerline of trap must be maintained for proper fit.
- Anchor hanger securely to wall using all six (6) 1/4 in. dia. mounting holes.

3. Install 3/8" IPS. female x 3/8" compression straight service stop to the building water inlet stub.

INSTALLATION OF COOLER

4. Hang the cooler on the hanger bracket. Be certain the hanger bracket is engaged properly in the slots on the cooler back as shown in Figure 2.
5. Loosen the two (2) screws holding the lower front panel at the bottom of cooler base and two (2) screws at the top. Remove the front panel and set aside.
6. Install a 3/8" O.D. water line between the service stop valve and cooler. Remove burr from outside of water line. Insert 3/8" O.D. water line in inlet side of "Y" strainer (see Fig. 3) to positive stop - approx. 3/4 inch. (See Fig. 4)

NOTE: If required, the 1/4" O.D. water inlet line to cooler may be cut to a desired length. However, if water line is cut, all burrs must be removed from outside of tube before inserting into the Y-strainer.

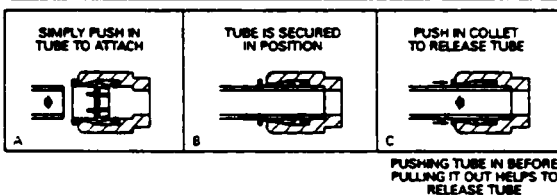

FIG. 4

PUSH BAR MECHANISM

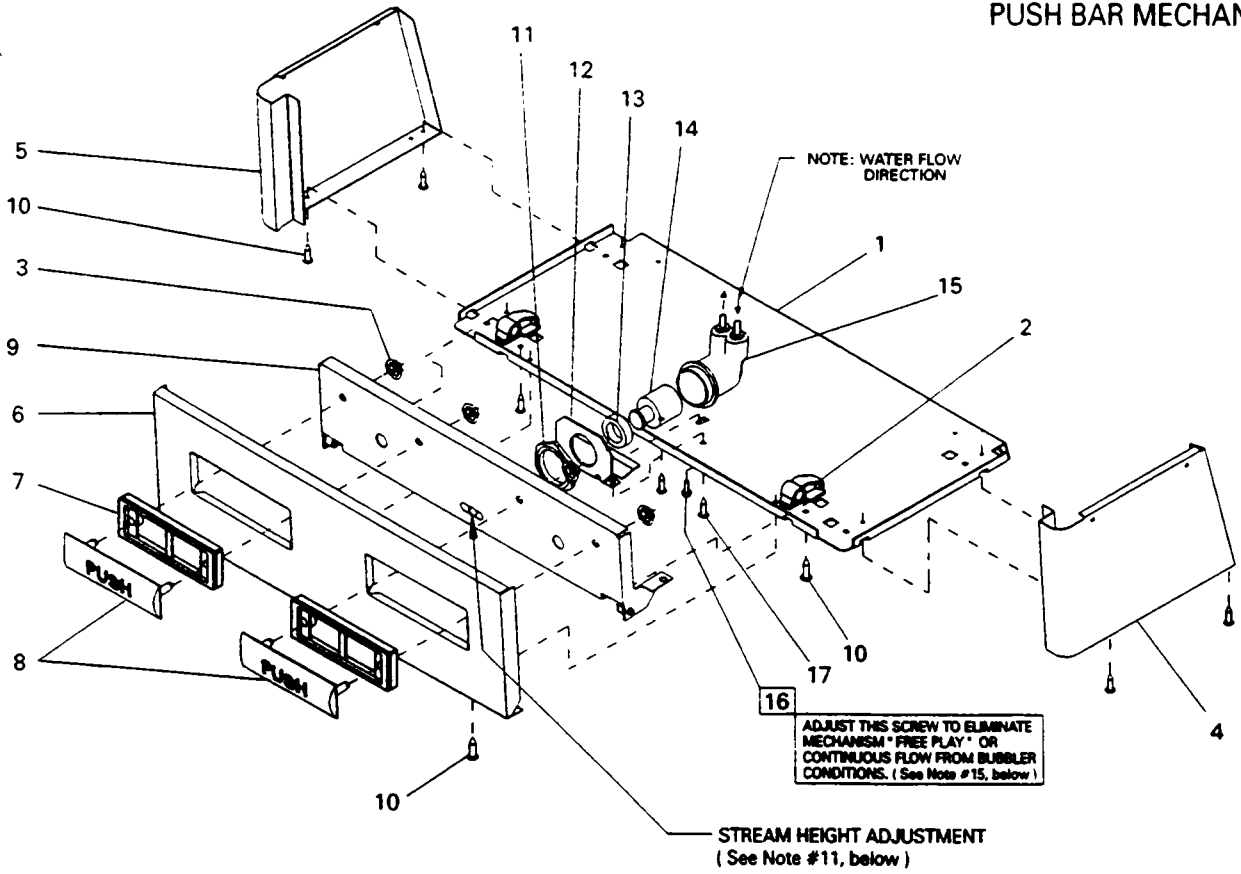

FIG. 5

8). Remove the slip nut and gasket from the trap and install them on the cooler waste line making sure that the end of the waste line fits into the trap. Assemble the slip nut and gasket to the trap and tighten securely.

START UP

- 9). Turn on the building water supply and check all connections for leaks.
- 10). Depress front push bar until all air is bled from cooler water system. A steady stream flow assures all air is removed.
- 11). Stream height is factory set at 45-50 PSI. If supply pressure varies greatly from this, readjust stream height to approximately 1-1/2" above the bubbler guard by turning adjustment screw, accessible by removing front push panel, item No. 6 (See Fig. 5 & 6)
- 12). Recheck all water and drain connections with water flowing through system.
- 13). Plug cooler power cord into building electrical receptacle protected by a Ground Fault Circuit Interrupter (GFCI).
- 14). Replace the front panel and secure by re-tightening the (4) screws.
- 15). **Water Valve Mechanism-ADJUSTMENT PROCEDURE:**
 - Turn adjustment screw (item #16) "Counter-Clockwise" until water flow from bubbler starts.
 - Turn adjustment screw "Clockwise" until water flow stops, THEN turn an additional 1/2 turn.

NOTE: Adjustments stated above are as viewed from underneath unit (bottom side of dispenser panel item #1).

PROTECT FROM FREEZING

- 16). If the ambient air temperature drops below freezing, the cooler needs to be drained of all water by blowing out all water lines and draining the evaporator (item #49) and the drain trap.
- 17). To drain the evaporator, remove styrofoam cap on bottom of evaporator and then remove drain plug (item #52). See Fig. 4.

ITEM NO.	PART NO.	DESCRIPTION
1	22897-C	Panel - Bottom Dispenser
2	51531-C	Block - Pivot
3	11-14117-43-620	Nut - 1/4 , Self-Threading
4	22822-C	Panel - Right Side
5	22814-C	Panel - Left Side
6	22806-C	Panel - Front Push
7	55859-C	Pushbar - Side & Front
8	10-15143-31-640	Insert - Push Bar, Chrome
9	22900-C	Bracket - Front Push
10	75499-C	Screw #8 x 5/8" Lg. Torx
11	40045-C	Hex Nut
12	23003-C	Bracket - Regulator Mounting
13	10031-C	Retaining Nut
14	61314-C	Regulator
15	50985-C	Holder - Regulator
16	70935-C	Screw - Shoulder x 1/2" Lg.
17	75500-C	Screw #10 x 1/2" Lg. Torx

CORRECT STREAM HEIGHT



FIG. 6

ITEM NO.	PART NO.	DESCRIPTION
18	31517-C	Power Cord
19	31475-C	Fan Blade (Use w/ Items 38 & 38a)
	30664-C	Fan Blade (Use w/ Item 38b)
20	70018-C	Hex Nut - Fan Blade
21	31490-C	Fan Motor (Use w/ Items 38 & 38a)
	31491-C	Fan Motor (Use w. Item 38b)
22	70009-C	Screw - (Fan Motor)
23	22899-C	Shroud - Fan
24	38417001	Screw - #8-18 x 3/8" Lg. (Fan Shroud)
25	75524-C	Clip (Front and Rear Panels)
26	27124-C	Cover - Cold Control
27	10079-C	Nipple - Bubbler
28	40-09423-08-640	Bubbler
29	10-03227-40-560	Gasket - Bubbler (upper and lower)
30	62152-C	Condenser
31	66202-C	Drier
32	22862-C	Panel - Right Rear
33	22854-C	Panel - Left Rear
34	22955-C	Panel - Front Lower
35	10-15161-43-550	Stud - Compressor Mtg.
36	10-08067-40-570	Grommet - Compressor Mtg.
37	19037000	Clip - Compressor Mtg.
38 *	35767-C	Compressor Serv. Pak FF7.5HBK
38a*	35761-C	Compressor Serv. Pak FF6HBK
38b*	35807-C	Compressor Serv. Pak AE3425Y
39	31025-C	Overload/Relay 1.350.358 (Use w/ Item 38)
	31026-C	Overload/Relay 1.350.356 (Use w. Item 38a)
	35801-C	Relay 9660-42-166 (Use w/ Item 38b)
	35795-C	Overload MRP26ALL-69 (Use w/ Item 38b)
40	35766-C	Cover - Terminal (Use w/ Item 38 & 38a)
	30181-C	Cover - Terminal (Use w/ Item 38b)
	30180-C	Overload Spring (Use w/ Item 38b)
	30182-C	Bale Strap (Use w/ Item 38b)
41	66214-C	Heat Exchanger (Use w/ Items 38 & 38b)
	66215-C	Heat Exchanger (Use w/ Item 38a)
42	45351-C	Waste Line
43	10-01471-40-560	Gasket - Drain
44	10-26399-31-640	Drain Plug
45	16-02705-08-640	Strainer Plate
46	22893-C	Basin
47	10-06876-08-640	Plug Button
48	31513-C	Cold Control
49	62220-C	Evaporator Assembly
50	70002-C	Screw - #10 x 1/2" Lg. HHSM
51	70767-C	Clip - Evaporator Retaining
52	70772-C	Plug - Drain
53	19-42439-01-550	Cover - Electrical Shield
54	55884-C	Elbow-Drain
55	55885-C	Nut 1-1/4 Slip Joint
56	70788-C	Y - Strainer (SEE FIG. 3 ON PAGE 2)
NOT SHOWN	40-06609-43-730	Hanger Bracket
NOT SHOWN	75519-C	Bit-Pinned Torx T-15
NOT SHOWN	75520-C	Bit-Pinned Torx T-25

* REPLACE WITH SAME COMPRESSOR USED IN ORIGINAL ASSEMBLY.
NOTE: All correspondence pertaining to Halsey Taylor water coolers or orders for repair parts MUST include Model No. and Serial No. of cooler, name and part number of replacement part.

TROUBLE SHOOTING & MAINTENANCE

1. Projector: If mineral deposits build up in the orifices, they can be removed by using a round file or small diameter wire
CAUTION: Care must be taken not to damage the orifices.
2. Stream Regulator: To adjust stream height see Instruction No. 11 under "START UP" Section on Page 3.
3. Temperature Control: Factory set for 50°F water ($\pm 5^\circ$) under normal conditions. For colder water, adjust screw on Item No. 14 (see Fig. 5 on Pg. 3), accessible by removing front panel (Item No. 6
CAUTION: Do not force screw against stops. Turn clockwise for colder water, counterclockwise for warmer.
4. Ventilation: Condenser fins (Item No. 30) should be periodically cleaned with a brush, air hose or vacuum cleaner.
5. Lubrication: Motors are lifetime lubricated.

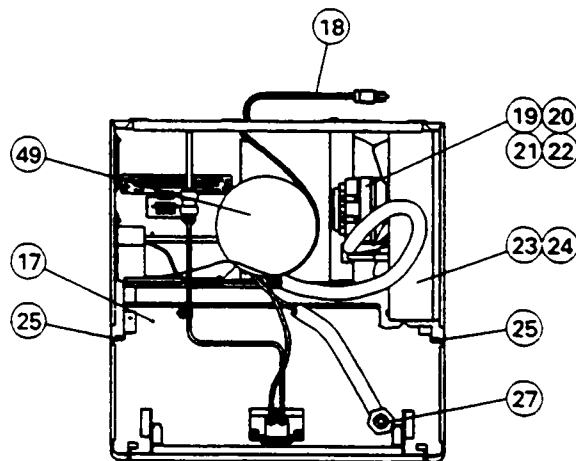

See Fig. 5 (on Page 3) for Push Bar Mechanism

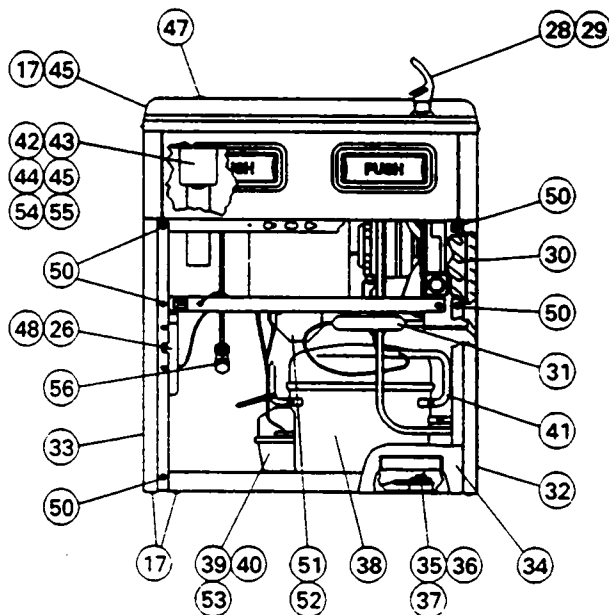

Halsey Taylor

P. O. BOX 9001
OAK BROOK, IL 60521
(708) 574-3500

FOR PARTS, CONTACT YOUR LOCAL DISTRIBUTOR OR CALL 1-800-323-0620