

FREEZE RESISTANT INSTALLATION KIT

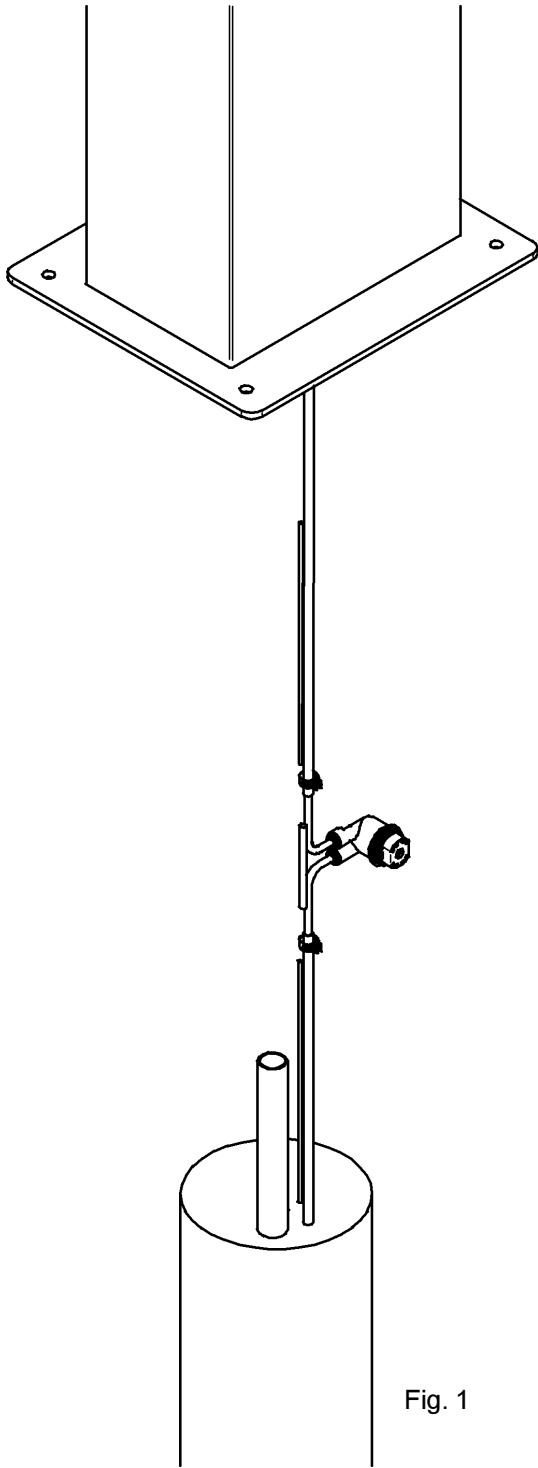

Fig. 1

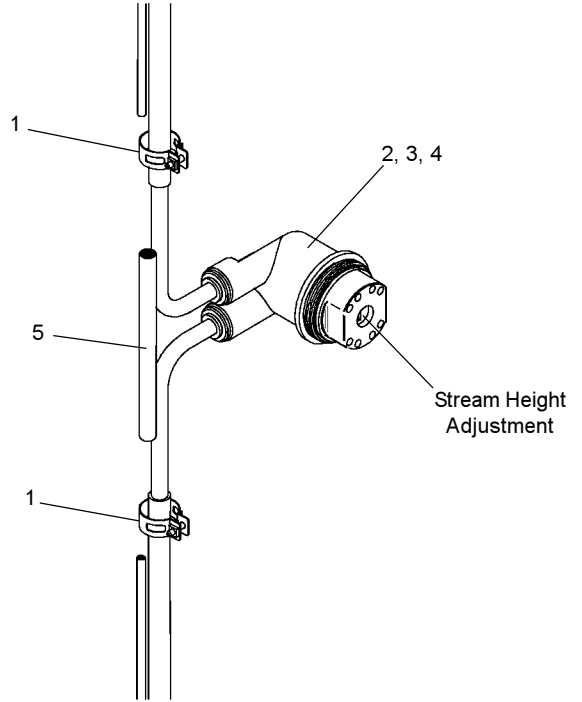

Fig. 2

Installation Instructions

Remove the PVC cap from the PVC column. This will require removing the fountain from the concrete pad. Remove the valve assembly from the PVC column by carefully pulling up on the connecting tubing. Cut a 6" piece out of the water supply line. **Be sure not to cut the air line.** Once water supply line is cut, insert the regulator/tube assy. and secure with clamps (See Fig. 2). Pressure test the valve assembly for leaks. Check stream height from the bubbler. Stream height is factory set at 35 PSI. If supply pressure varies greatly from this adjust the screw on item 4. Clockwise adjustment will raise stream and counter-clockwise adjustment will lower stream. For best adjustment stream height should be approximately 1-1/2" (38mm) above the bubbler guard. Replace the water valve into the PVC column. Make sure the supply hose coils into the bottom of the PVC column without any kinks and double check that the water valve is positioned fully at the bottom of the PVC column. Cap the PVC column and re-mount the fountain.

PARTS LIST

ITEM NO.	PART NO.	DESCRIPTION
1	101449542550	HOSE CLAMP
2	50986C	REGULATOR HOLDER
3	56082C	REGULATOR NUT
4	61313C	REGULATOR
5	66719C	TUBE ASSEMBLY

Halsey Taylor
 2222 CAMDEN COURT
 OAK BROOK, IL 60523
 630.574.3500