

Installation Instructions

Cane Touch Apron

TOOLS REQUIRED:

- Phillips Head Screwdriver
- Torx Head Driver
- Power Drill with 1/8" Drill Bit
- Hammer and Center Punch

INSTALLATION PROCEDURE:

- 1) Using template provided mark hole locations on front of left and right side panels.

TOP - Align with corner between side panel and dispenser panel. (See Fig. 1, Item A)

OUTSIDE EDGE - Align with outside edge of side panels. (See Fig. 1, Item B)

- 2) Drill 1/8" diameter holes at marked locations. (Center punch hole locations before drilling) When drilling the right hand hole, on refrigeration units, be certain to drill straight.

CAUTION: Keep the drill bit away from the refrigeration condenser. If the drill damages or punctures the condenser refrigeration tubing severe and expensive damage to the refrigeration system will result.

- 3) Loosen and remove screws from underside of cooler/fountain dispenser panels.
- 4) Install cane touch apron to underside of cooler/fountain dispenser panels.
- 5) Reuse fasteners removed in step 3 above.
- 6) Attach lower edges of apron to cooler side panels with screws provided. (Using two holes drilled in step 2 above)

CANE TOUCH APRON COLOR OPTIONS:

PART NO.	FINISH
26779C	Almond Vinyl
26783C	Stainless Steel
26811C	Slate Vinyl
27621C	Aztec Gold
26814C	Platinum Vinyl

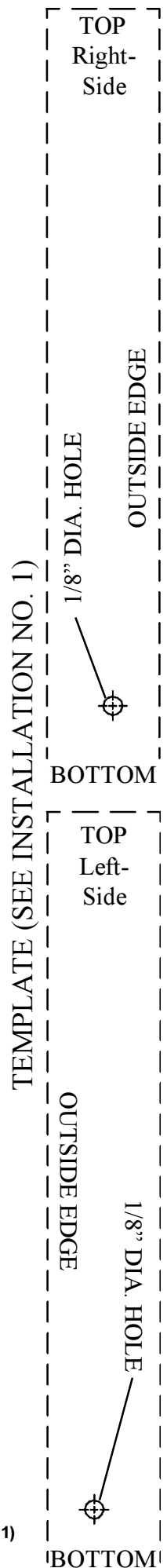

UNIT (W/O REFRIG.)

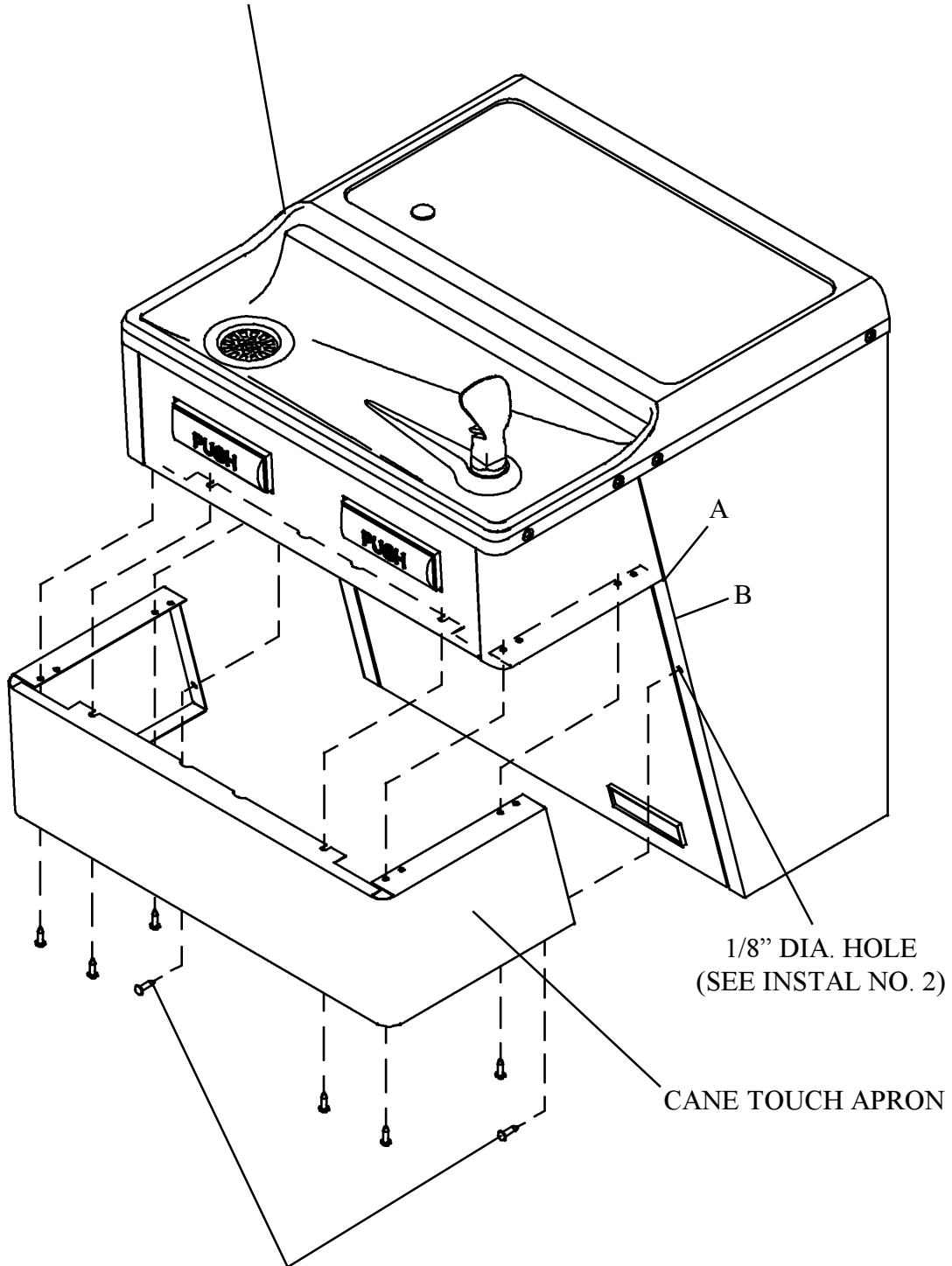

1/8" DIA. HOLE
(SEE INSTAL NO. 2)

CANE TOUCH APRON

SEE INSTALLATION NO. 6

FOR PARTS, CONTACT YOUR LOCAL DISTRIBUTOR OR CALL 1.800.323.0620
HALSEY TAYLOR COMPANY • 2222 CAMDEN COURT • OAK BROOK, IL 60523 • 630.574.3500